

**Liliya Morska**

# **English 8**

# **Workbook**

***Робочий зошит до підручника  
«Англійська мова. 8 клас»  
(автор Лілія Морська)***

Тернопіль  
Астон  
2017

ББК 81.43.21-922  
М80

**Морська Л. І.**

М80 English 8. Workbook. Англійська мова 8. Робочий зошит. – Тернопіль : Астон, 2016. – 128 с.  
ISBN 978-966-308-696-5

Робочий зошит розроблено відповідно до змісту підручника з метою кращого засвоєння основного навчального матеріалу. Подані вправи і завдання забезпечують розвиток сформованих на уроці граматичних і лексичних навичок, умінь писемного мовлення. Зошит можна використовувати як для виконання домашнього завдання, так і для індивідуалізації чи диференціації навчального процесу під час уроку.

**ISBN 978-966-308-696-5**

© Морська Л. І., 2017  
© ТзОВ «Видавництво Астон», 2017

# REVISION LESSON

## Lesson 1

### 1. Read the text below. Choose the right word to fill in the gaps.

The summer is one of the four 1) A) seasons, alongside with the winter, autumn and spring. Summer 2) \_\_\_\_\_ offer many new adventures and impressions for both adults and children. Many people prefer going to the seaside for vacations, while the others choose the mountain 3) \_\_\_\_\_. Summer is a perfect time to 4) \_\_\_\_\_ a new city and discover new culture and traditions. Visiting a new city allows 5) \_\_\_\_\_ interesting pictures and 6) \_\_\_\_\_ new dishes of the local cuisine. Many people 7) \_\_\_\_\_ a picnic in summer, as the weather is mostly sunny and warm. Children like to ride the bicycles, roller-skate and play 8) \_\_\_\_\_ in summer. Moreover, summer offers many 9) \_\_\_\_\_ sport activities, like kayaking, rafting, skydiving, surfing, parachute-10) \_\_\_\_\_ and others. In any case, summer is the period of bright experience, unforgettable emotions and amusing moments.

	A	B	C	D
1.	seasons;	times;	periods;	moments.
2.	vacations;	rest;	holidays;	relaxation.
3.	walking;	hiking;	wandering;	strolling.
4.	visit;	attend	move;	watch.
5.	showing;	grabbing;	watching;	taking.
6.	tasting;	trying;	observing;	cooking.
7.	move to;	go for;	drive to;	take.
8.	inside;	open-air;	outdoors;	indoors.
9.	dangerous;	exotic;	extreme;	unusual.
10.	sliding;	falling;	springing;	jumping.

### 2. Make up sentences in the Present Perfect, using the words below.

1. Marta/ never/ watch/ this/ before/ movie:

*Marta has never watched this movie before.*

---

2. We/ take/ many/ pictures/ from/ our holidays/ Poland:

---

3. He/ lose/ mobile phone/ seaside:

---

4. Her parents/ but/ new/ bicycle/ for/ riding/ around/ the city:

---

5. They/ be/ Great Britain / three times:

---

6. You /finish/ your homework/ on time:

---

7. I/ forget/ to take/ many/ pictures/ my holidays/ mountains:

---

## Lesson 2

### 1. Complete the crossword puzzle.

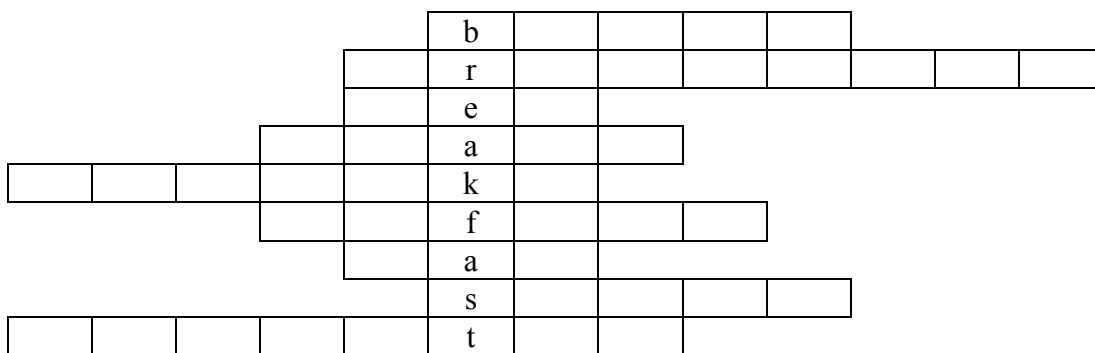

1. \_\_\_\_\_ is a pork product and one of the most popular food choices for the breakfast, made by people in the UK;

2. \_\_\_\_\_ is a type of pastry with fruit or cream filling, originated in France and eaten all over the world for breakfast;

3. \_\_\_\_\_ is a hot drink, which is made of the plant leaves or grass;

4. \_\_\_\_\_ is a slice of bread, fried or cooked under the grill until it gets brown.

5. \_\_\_\_\_ is a flat cake, which is fried or roasted from both sides.

6. \_\_\_\_\_ is a hot beverage, made of the roasted coffee beans and hot milk.

7. \_\_\_\_\_ is a substance, made of fruit or berries, which is put on the bread.

8. \_\_\_\_\_ is a fresh mix of vegetables or fruit with a special dressing.

9. \_\_\_\_\_ is a name of a dish, made of the fried eggs, parsley, onions and salt.

## 2. Circle out the odd word and explain your choice.

*Model: Burgers – French fries – (apples) – nuggets. Apples is the odd word, as it is the only word from the list, which does not belong to the fast food.*

1. Orange – pear – peach – potato;
2. Croissants – bread – sausage – pancakes;
3. Bacon – egg – sausage – ham;
4. Juice – coffee – tea – hot chocolate;
5. Fish-and-chips – roasted turkey – tiramisu – meat pudding;
6. Snack – appetizer – starter – main course;
7. Breakfast – salad – dinner – brunch.

## 3. Put the verbs in brackets into the correct tense forms.

Maria \_\_\_\_\_ (decide) to cook the pasta with tomatoes and oregano. First, she \_\_\_\_\_ (chop) some onions and carrots and \_\_\_\_\_ (put) them into a big plate. Then, she \_\_\_\_\_ (boil) the pasta for about 15 minutes. During that time, she \_\_\_\_\_ (cut) the tomatoes and \_\_\_\_\_ (add) some salt, pepper and oregano. Later, she \_\_\_\_\_ (mix) the vegetables together and \_\_\_\_\_ (take) the cooked pasta from the pan. She \_\_\_\_\_ (add) vegetables to the pasta and \_\_\_\_\_ (put) the spicy dressing on top. After eating, Maria \_\_\_\_\_ (wash) the dishes and \_\_\_\_\_ (cleaned) the table.

## Lesson 3

### 1. Complete the sentences below, adding the information about your hobbies.

*Model: I used to play volleyball, when I visited my friends in the countryside.*

1. I used to \_\_\_\_\_, when I was a small child.
2. I used to \_\_\_\_\_, in 2010.
3. I used to \_\_\_\_\_, when I started going to school.
4. I used to \_\_\_\_\_, when I was studying in the primary school.
5. I used to \_\_\_\_\_, when I went for holidays with my parents.
6. I used to \_\_\_\_\_, when I had my summer holidays.
7. I used to \_\_\_\_\_ after finishing my homework.
8. I used to \_\_\_\_\_ for 5 years.

**2. Find out the meanings of the following idioms. Then complete the sentences with the correct ones.**

*To sell something like hot cakes    to have a sweet tooth    bread and butter  
To have egg on one's face    a piece of cake    to make one's mouth water*

1. The smell of cakes from the confectionary has \_\_\_\_\_.
2. He can tell you a lot about cars, as mechanics is his \_\_\_\_\_.
3. My mother often bakes apple pies and croissants with jams, because she knows that I \_\_\_\_\_.
4. Dancing samba is \_\_\_\_\_ for her, because she has been practising it for about 7 years.
5. Marta has not done her homework, so she felt like she \_\_\_\_\_ in the classroom.
6. Samsung \_\_\_\_\_ its new devices \_\_\_\_\_, because of their high quality and good technical characteristics.

## Unit 1. MY FRIENDS

### Lesson 4

**1. Look at the following icons. Which social networks do they represent? Write down the names and use them to complete the sentences below.**

1. \_\_\_\_\_
2. \_\_\_\_\_
3. \_\_\_\_\_
4. \_\_\_\_\_
5. \_\_\_\_\_
6. \_\_\_\_\_



1. Since Ivan travels a lot, he writes different stories about trips and post them on the blogging platform, called \_\_\_\_\_.

2. If you find an interesting book, postcard, handmade toy or jewelry, you should share it via \_\_\_\_\_, which gathers all the beautiful things in one place.

3. Many people find it difficult to lead an account in \_\_\_\_\_, as it allows posting only short messages.

4. Lida is a professional photographer, and she keeps showing her pictures on her \_\_\_\_\_ page.

5. Anton likes shooting videos about nature and posting them on \_\_\_\_\_, where everyone can watch them.

6. \_\_\_\_\_ remains one of the most popular social network, which operates all over the world.

**2. Write down the activities you can do together with your friends in different situations.**

<b>Activities outdoors</b>	<b>Activities indoors</b>	<b>Activities on the Internet</b>
<i>Playing volley-ball</i>	<i>Watching movies</i>	<i>Chatting via Facebook</i>

**3. Choose the right word to fill in the gaps and translate the sentences into Ukrainian.**

*Model: The majority of teenagers use the \_\_\_\_\_ (social/civil) networks to communicate with each other.*

1. Nowadays, you do not need to print all the photos, because you can store them in a \_\_\_\_\_ (Internet/ digital) format.

2. Internet and social networks help people to \_\_\_\_\_ (keep/ feel) in touch with each other even on the long distances.

3. Maria has lost her \_\_\_\_\_ (cell/ conventional) phone, when she was on the excursion.

4. Many companies create their personal \_\_\_\_\_ (windows/ webpages) to communicate with the customers and spread information about their products and services.

5. Skype has many useful options. For example, a \_\_\_\_\_ (audio/ video) call allows you both hearing and seeing the person.

6. Some studying materials are available only \_\_\_\_\_ (online/ distantly), so you need to have good Internet connection to access them.

7. When you fly by plane, you need to turn on the \_\_\_\_\_ (flying/ airplane) mode on your electronic devices.

## **Lesson 5**

**1. Read the text. Fill in the gaps with the words from the box below.**

<i>Charger</i>	<i>cell phone</i>	<i>USB cable</i>	<i>Internet</i>
<i>Wi-Fi</i>	<i>earphones</i>	<i>microphone</i>	<i>e-mails</i>
	<i>video</i>	<i>laptop</i>	

Next week, Artem is leaving home for Greece on vacations. He plans to take his laptop and new \_\_\_\_\_ with him. Artem wants to take his \_\_\_\_\_ to be able to listen to the music on the road. Moreover, he needs to take a \_\_\_\_\_ to



recharge the battery of his \_\_\_\_\_ and mobile phone. Before traveling, Artem plans to check the \_\_\_\_\_ of the phone to be able to speak with his friends and relatives. It is also useful to take the \_\_\_\_\_ to connect the cell phone to the laptop easily. Artem is certain that he will use the \_\_\_\_\_ to keep in touch with his friends. That is why he wants to be sure the \_\_\_\_\_ network functions well. Artem knows that he will have good vacations, because he will be able to make \_\_\_\_\_ calls and send \_\_\_\_\_ to his relatives and classmates.

**2. Complete the sentences using the right tense form.**

1. Maria \_\_\_\_\_ (to leave) to Germany for holidays next Sunday.
2. My friend \_\_\_\_\_ (to go) to the theatre with his parents to watch a new performance.
3. We always \_\_\_\_\_ (to play football) on Sundays, if the weather is sunny.
4. I cannot answer the call now, because I \_\_\_\_\_ (to study), at the moment.
5. They \_\_\_\_\_ (to stay) in this town for two more weeks.
6. She regularly \_\_\_\_\_ (to post) pictures on her Facebook account to let her friends know about her trips.
7. Oksana \_\_\_\_\_ (to visit) her grandparents tonight and that is why she cannot go to the cinema with her classmates.

**Lesson 6**

**Fill in the gaps with the correct indefinite pronouns or adverbs.**

1. Will you call \_\_\_\_\_ else for your birthday party, except your classmates?
2. I did not find \_\_\_\_\_ to eat in the fridge.
3. They had booked a good hotel in Berlin, but then decided to stay \_\_\_\_\_ else.
4. He would like to read \_\_\_\_\_ else for this lesson.
5. I would like to speak with \_\_\_\_\_, who can repair the electronic devices.

6. After a long and exhausting journey, we hardly could find \_\_\_\_\_ to show us a road back.

7. Would you like \_\_\_\_\_ else to eat after the main course?

8. He did not stop \_\_\_\_\_ on his way to the seaside.

9. I will be glad to cook \_\_\_\_\_ together with my friends, when we go for a picnic.

10. Because this room looked so empty, we understood that \_\_\_\_\_ was living there.

**2. Read the following affirmative sentences. Rewrite them according to the model.**

*Model: There is something on the floor.*

*Is there anything on the floor?*

*There is nothing on the floor.*

1. There is somebody, standing in the middle of the street.

---

2. They stopped somewhere to have lunch, as they were going for the excursion.

---

3. I find something interesting in this picture, because it reminds me about my childhood.

---

4. Next time, they will stop somewhere else, because this hotel does not provide good services.

---

5. There is something broken on the stairs.

---

6. I know somebody, who can fix all the problems with the Internet connection and functioning of the social networks.

---

7. She wants to go somewhere else after the cinema.

## Lesson 7

**1. Look at the sentences below. What do they express? Sort them out in the following groups.**

Future plans and arrangements	Future actions on the timetable	Intentions and predictions based on what we see	Promises and predictions based on what we know

1. It is going to rain soon, as there are many dark clouds. 2. The plane takes off at 13.45. 3. I am visiting my grandparents next week. 4. I will buy a new laptop, when I save aside enough money. 5. The train arrives at midnight to the central railway station. 6. She is going to play tennis, because she has her racket with her. 7. You are leaving for Spain these weekend, aren't you? 8. I will be glad to meet up with my classmates on the weekend. 9. He will win this competition, as he is practising a lot. 10. We are celebrating the New Year's Eve on Sunday. 11. He is going to pack his luggage later tonight. 12. My bus departs at 12 o'clock. 13. My train will be delayed due to the weather conditions. 14. The electric cars will replace the mechanic ones in the near future. 15. I am staying in this hotel for two more weeks.

**2. Fill in the gaps with the verbs in the correct tense forms. Explain your choice.**

1. According to the survey, more schoolchildren \_\_\_\_\_ (use) Facebook in the recent years.

2. The main reason \_\_\_\_\_ (be) the possibility to communicate with each other via social networks.
3. Social networks \_\_\_\_\_ (replace) the traditional methods of communication in the future.
4. Mark \_\_\_\_\_(leave) to the seaside with his family next week. He \_\_\_\_\_(post) everything about his journey on his Facebook account.
5. My cell phone has broken. I \_\_\_\_\_(take) it to the service center tomorrow.
6. She has forgotten to take the charger. She \_\_\_\_\_(use) the USB cable to charge the cell phone.
7. We hope that our hotel \_\_\_\_\_(have) the free Wi-Fi network for the guests.

## Lesson 8

**1. Choose the correct word from the box to complete the sentences. Use the model to help you.**

<i>Popular</i>	<i>fast</i>	<i>hard</i>
<i>delicious</i>	<i>exciting</i>	
<i>difficult</i>	<i>powerful</i>	<i>expensive</i>

*Model: My new laptop is \_\_\_\_\_ yours.*

*My new laptop is as powerful as yours.*

1. This hotel is not \_\_\_\_\_ the one, situated at the seaside.
2. Twitter is not \_\_\_\_\_ Facebook.
3. This apple pie is \_\_\_\_\_ tiramisu.
4. Playing tennis is \_\_\_\_\_ dancing.
5. He is studying \_\_\_\_\_ he can.
6. Walking around the city is not \_\_\_\_\_ driving a car.
7. This movie is \_\_\_\_\_ the book, it was based on.

## **2. Choose the right word to complete the sentences.**

1. Marta is very \_\_\_\_\_ (stubborn/ patient). She can study for a long period without breaks or wait in the long queues without getting irritated.

2. Igor is very \_\_\_\_\_ (sociable/ decisive). He has many friends and enjoys spending time together with his classmates and relatives.

3. Liza is \_\_\_\_\_ (generous/ honest). She never lies to her friends and is eager to share the truthful information with others.

4. Anton is \_\_\_\_\_ (hospitable/ greedy). Although he likes spending time with his friends, he does not want to spend much money.

5. Oksana is \_\_\_\_\_ (decisive/ intelligent). She always decides where to go in the evening and plans the future trips with her friends.

6. Mark is \_\_\_\_\_ (hospitable/ lazy). Sometimes he organizes meetings with his friends, but he does not like to prepare the celebration or clean up the place for the meeting.

7. Maria is \_\_\_\_\_ (intelligent/ brave). She knows a lot about geography and can tell many interesting facts about every country.

8. Oleg is \_\_\_\_\_ (stubborn / hospitable). He always organizes good parties with his friends and likes to welcome guests in his house.

## **3. Write down the antonyms to the given words.**

*Model: greedy – generous;*

*honest – dishonest.*

1. Hospitable – \_\_\_\_\_

2. Patient – \_\_\_\_\_

3. Stubborn – \_\_\_\_\_

4. Intelligent – \_\_\_\_\_

5. Sociable – \_\_\_\_\_

6. Brave – \_\_\_\_\_

7. Lazy – \_\_\_\_\_

8. Decisive – \_\_\_\_\_

## Lesson 9

### **1. Fill in the gaps with the comparison as...as and the correct tense form of the verb.**

1. These apples (not/ taste / good) *do not taste as good as* the ones I bought last week.

2. My cell phone (not / trendy / be) \_\_\_\_\_ yours.

3. Mark (hospitable / sociable / be) \_\_\_\_\_ his parents.

4. Writing letters (not / effective/ be) \_\_\_\_\_ sending e-mails.

5. Communicating on the Internet (not/ exciting) \_\_\_\_\_ meeting with the friends.

6. Manuel (decisive / be) \_\_\_\_\_ as his classmates.

7. Pisces (not / curious and active / be) \_\_\_\_\_ Gemini.

8. Star Wars II (not/ interesting / be) \_\_\_\_\_ Star Wars I.

### **2. Read the following sentences. Find the mistakes and correct them.**

1. This building is as taller as my house.

2. Mine laptop does not work without the charger.

3. I used to lived with my grandparents during first five years of my life.

4. Oksana is very greedy. She always shares sweets and fruit with her friends and classmates.

5. The train will depart at 1:25 am from the main railway station.

6. I would like to talk to anybody, who understands English.

7. There is not nobody in that room.

8. I go to Spain next weekend.

9. Ternopil is as big as not Lviv.

10. I think he must be very impatient, because he can wait in the long queues without getting irritated or angry.

### **3. Read the following characteristics of people. Think about the ways of improving them.**

*Model: Incompetent. If a person is incompetent, he/ she should study more to get the needed knowledge.*

1. Lazy: \_\_\_\_\_
2. Unhospitable: \_\_\_\_\_
3. Impatient: \_\_\_\_\_
4. Dishonest: \_\_\_\_\_
5. Unfriendly: \_\_\_\_\_
6. Greedy: \_\_\_\_\_

## Lesson 10

### 1. Complete the sentences using the words from the box below.

<i>password</i>	<i>talkative</i>	<i>call</i>	<i>USB cable</i>
<i>sociable</i>	<i>e-mail</i>	<i>cell phone</i>	
<i>webpage</i>	<i>Skype</i>	<i>gadgets</i>	

1. You do not have to pay the phone bills, if you want to send an \_\_\_\_\_ to your friends.
2. In my opinion, she is very \_\_\_\_\_, as she always texts her friends and chats via social networks.
3. I have no idea where is my \_\_\_\_\_. I need to find it to connect my cell phone to the laptop to upload the new pictures from the trip.
4. My mum often uses her \_\_\_\_\_, as she likes to call her friends and speak with the relatives.
5. It is important to remember your \_\_\_\_\_, if you want to access your personal accounts in the social networks.
6. This company has a very good \_\_\_\_\_, where you can read the description of all products.
7. One needs to have a good Internet connection to be able to make video calls via \_\_\_\_\_.
8. Sometimes it is faster and more effective to make a \_\_\_\_\_ than send a message via the Internet.
9. Nowadays, everyone can afford buying electronic devices and \_\_\_\_\_, as the price range varies a lot.
10. It is estimated that social networks make people more sociable and \_\_\_\_\_.

**2. Read at the situations described below. Write down which mode of communication you will chose for each of them.**

*Model: You need to organize a party with many people.*

*To organize a party with many people, I will send the e-mails with invitations.*

1. You need to tell your parents you will come later. \_\_\_\_\_

2. You want to share pictures from your last journey. \_\_\_\_\_

3. You have to contact your teacher to clarify the date of the exam. \_\_\_\_\_

4. You want to invite your friend to the cinema. \_\_\_\_\_

5. You need to contact your friend who lives abroad. \_\_\_\_\_

## **Lesson 11**

**1. Read the letter to a pen friend. Put the paragraphs in the right order.**

I am glad to hear that everything is OK with you and your family. It was interesting to read about your last journey. I would also like to visit Slovakia one day. Thank you for such a detailed description of the resort, nature and your impressions. Have you made any new friends while travelling?

Hello, dear Jane! Thank you for your letter! It is nice to hear from you. Hope you are doing well now.

Thank you again for your letter! Send my greetings to your brother and parents! Hope to meet you soon! Have a nice day!

As for me, I am visiting England next week together with my family. We are going to stay in London for a few days in a small apartment. I am planning to go sightseeing and visit some museums. I will post some pictures on my Facebook page, so you can see them as well.

Hugs,

Tom.



**2. Read the description of people. Decide, which traits of character they may have.**

*Model: Mark is a leader of a big international company. He works a lot with people and solves many business tasks. Mark often visits international conferences and communicates with the colleagues from all over the world.*

*In my opinion, Mark is intelligent, decisive, active, sociable and confident.*

1. Oksana works for a charity organization. She helps to rescue injured wild animals and take care of them. Oksana likes to help others and share her knowledge with other people.

In my opinion, Oksana is \_\_\_\_\_

2. Artem is a pupil of the 8<sup>th</sup> form. He likes such subjects as Physics, Mathematics and Biology. He plans to become a scientist or a doctor after graduating from the university. Artem often participates in the competitions and wins medals.

In my opinion, Artem is \_\_\_\_\_

3. Liza is a student of the pedagogical university. She likes to communicate with people and she actively uses the social networks to keep in touch with her friends and relatives. She is a good friend who is always ready to help others.

In my opinion, Liza is \_\_\_\_\_

4. Andrii is a journalist. He searches for the truthful information to present it to the public. Andrii likes to communicate with people, because he often has to take interviews and speak with the witnesses of different events.

In my opinion, Andrii is \_\_\_\_\_

5. Kateryna is a mother of three children. She spends much time with them and knows how to organize their free time. Kateryna knows many games and activities and adores working with the children.

In my opinion, Kateryna is \_\_\_\_\_

## Lesson 12

**1. Read the sentences below. Guess which zodiac signs are described.**

1. Those people do not like to work in the office, because they are very creative and talented.

2. People of this sign prefer spending their vacations at home, because they do not like travelling or active holidays.

3. These people are very unpredictable, because they frequently change their mood preferences and interests.

4. People, born under this zodiac sign, enjoy active rest, sports activities and travelling, though they need help in managing their finances.

5. People of this sign are selfish and self-oriented, though they can also be very romantic, generous and hospitable.

6. Those people are very punctual, and they will rarely come late for the interview or meeting.

7. These people are good workers, because they are quite patient, hard-working, reliable and self-organized.

**2. Imagine you are travelling to Italy for vacations. Complete the dialogue, using Future Simple or Present Continuous.**

A: So, are you leaving for Italy next week?

B: \_\_\_\_\_

A: How much time are you planning to stay there?

B: \_\_\_\_\_

A: What are you going to do there?

B: \_\_\_\_\_

A: Will you travel to Rome or will you stay at the seaside?

B: \_\_\_\_\_

A: Do you know which souvenirs you want to buy?

B: \_\_\_\_\_

A: Will you post any pictures from your journey on Instagram?

B: \_\_\_\_\_

**3. Write down the answers to the e-mails:**

*Dear friend! I would like to invite you to my birthday party, which takes place on Sep 23, at 4 pm. I would be glad to see you at the party. I am waiting for your response!*

---

---

---

---

---

Hello! How is your journey to Poland going? I will be in Warsaw next weekend. It would be nice to meet there. Looking forward to hearing from you!

---

---

---

---

---

Dear customer,  
Your package has been delivered to the post office. Please, come to receive it today till 6 pm. You need to have your passport with you.

---

---

---

---

---

## Lesson 13

### 1. Write down the traits of character of a good:

Teacher	Police Officer	Parent	President	Student

### 2. Put the verbs in brackets into Present Continuous, Present Simple or Future Simple.

1. I \_\_\_\_\_ (travel) to Poland next summer to visit my relatives.
2. There \_\_\_\_\_ (be) any discounts in the shops at the end of the summer?
3. We \_\_\_\_\_ (stay) in this city till the end of our journey, as it is lovely and not very expensive.
4. They \_\_\_ probably \_\_\_\_\_ (buy) a new car, because they have been putting money aside during the entire year.
5. My plane \_\_\_\_\_ (take off) at noon, though there may be some delays.
6. Marta \_\_\_\_\_ (participate) in the sports competition next Sunday. She is a good athlete, so she \_\_\_\_\_ (win) some medals.
7. Linda \_\_\_\_\_ (graduate) school in a month. After that she \_\_\_\_\_ (plan) to continue studying at university.
8. I \_\_\_\_\_ (stop) at this hotel, unless I find a better choice.
9. This company \_\_\_\_\_ (start) selling its new electronic devices in two weeks. Many people \_\_\_\_\_ (plan) to buy them as soon as they enter the market.
10. She \_\_\_\_\_ (leave) for Kyiv by train, which \_\_\_\_\_ (depart) from the station at 11 pm.

### 3. Complete in the crossword puzzle:

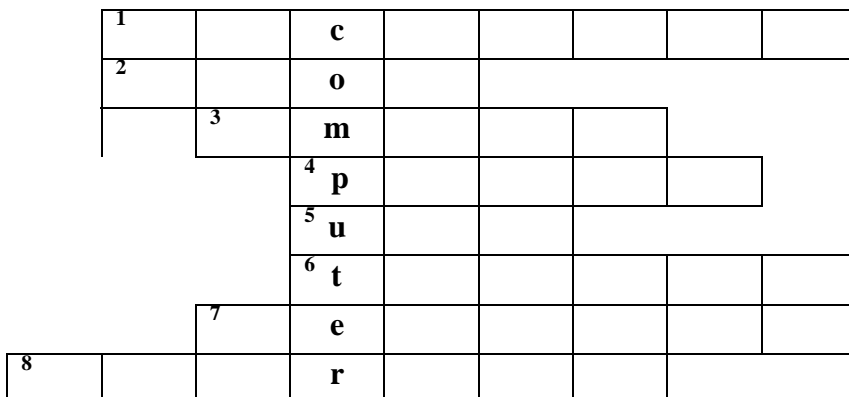

1. It is the most famous and well-known social network, used for posting pictures, communicating with friends and sending instant messages.
2. It is a web page for writing texts and small stories, dedicated to a certain topic.
3. It is a type of postal services, which are conducted online and with the help of the Internet.
4. This electronic device is used to make calls and send messages.
5. This cable serves in order to connect different electronic devices with each other.
6. This gadget is bigger than a smartphone and smaller than a netbook. It does not have a keyboard. It is used for surfing the Internet and seeking information.
7. This is a small communication report or notification; the friends use smartphones to send it to each other.
8. This appliance is used to charge the electronic devices and gadgets.

## Lesson 14

### 1. Complete the sentences using the words from the box below.

<i>Face-to-face conversation</i>	<i>netbook</i>	<i>blog</i>	<i>body language</i>
<i>computer networks</i>	<i>postal services</i>	<i>text messages</i>	

1. Without doubts, verbal information is important for understanding each other, though the greatest role in communication belongs to the \_\_\_\_\_.

2. It is true that the Internet helps to keep in touch with friends on distance, though it cannot replace the real \_\_\_\_\_.

3. When I was planning a trip to Indonesia, I looked through many Internet \_\_\_\_\_, written by the travelers who had visited this country before.

4. \_\_\_\_\_ is a type of electronic devices, which is used primarily for surfing the net and searching for the information.

5. Despite the rapid development of new technologies, many people still apply to the \_\_\_\_\_ to send the material gifts and postcards to their friends.

6. It is prohibited to make calls or send \_\_\_\_\_ while driving, as it can distract drivers' attention from the road.

7. The Internet is a type of \_\_\_\_\_, which helps to share the information between a certain amount of computers at the same time.

**2. Make up a mind map about digital technologies. Use as many words as possible:**

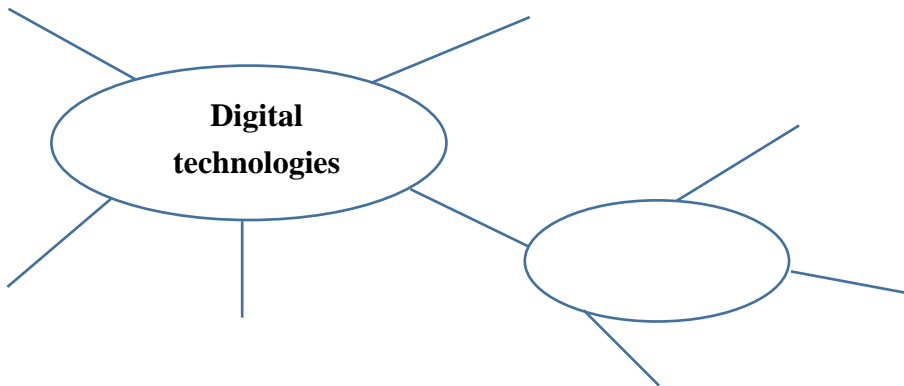

**3. Write down the sentences to describe the traits of character of the following people.**

1. In my opinion, a good doctor should be \_\_\_\_\_.

2. In my opinion, a perfect friend should be \_\_\_\_\_.

3. In my opinion, a professional lawyer should be \_\_\_\_\_.

4. In my opinion, a deligent student should be \_\_\_\_\_.

5. In my opinion, a good leader should be \_\_\_\_\_.

## Lesson 15 (Optional)

## Unit 2. HEALTHY LIFESTYLE

### Lesson 16

#### 1. Fill in with many or much.

1. We cannot see \_\_\_\_\_ grass in winter.
2. Marta likes shopping, but I think she spends too \_\_\_\_\_ money on clothes.
3. There weren't \_\_\_\_\_ buses at the bus stop yesterday.
4. My father would like to buy a dog, but he does not know which one exactly, as there are so \_\_\_\_\_ different breeds of dogs.
5. If you make \_\_\_\_\_ mistakes in the test, you will not pass it.
6. Last night there was so \_\_\_\_\_ noise outside that I could not sleep.
7. Do you use \_\_\_\_\_ social networks to keep in touch with your friends?
8. Oleg does not have \_\_\_\_\_ time to listen to the music.
9. Thank you so \_\_\_\_\_ for your good advice.
10. I like to get acquainted with \_\_\_\_\_ different people from around the world.

#### 2. Match the questions from Column A with the right answers from Column B.

Column A	Column B
How many tomatoes has she got in her bag?	A. There are five pears.
How much are the beetroots?	B. It's 25 hryvnas.
How many carrots are there?	C. They are 10 hryvnas per kilogram.
How many cabbages do they have?	D. She has got eight tomatoes.
How much is the pork?	E. I can see five bananas.
How many bananas can you see in the fridge?	F. They have about 12 cabbages.

**3. Read the sentences below and guess what they express. Sort them out into the following groups.**

<b>Recommendation</b>	<b>Advice</b>	<b>Obligation</b>	<b>Prohibition</b>

1. You should see your doctor immediately to protect your health!
2. You should not eat too much fatty and fried food.
3. You should start jogging in the mornings. It is good for your health and well-being.
4. If you have time, you should read this book. I find it quite interesting.
5. Parents should not leave their small children alone in the flat.
6. People with the diabetes should avoid food which contains natural sugar.
7. You should eat many vegetables, as they are good for your health.
8. You should visit Warsaw, when you are in Poland.
9. You should not watch the TV much, as it negatively influences your eyes.
10. You should be at the theatre in time. Don't be late!



# Lesson 17

1. Look at the following safety signs. Then write the sentences as in the model.

Model: You should not smoke.

You should not use the naked flames.



No  
Smoking



No  
naked flames



No  
pedestrians



No  
food/drink



Not for  
drinking



No  
gloves



No  
alcohol



No  
thongs



No  
mobiles



No  
sharps



No  
skates



No  
Cycles

3. \_\_\_\_\_
4. \_\_\_\_\_
5. \_\_\_\_\_
6. \_\_\_\_\_
7. \_\_\_\_\_
8. \_\_\_\_\_
9. \_\_\_\_\_
10. \_\_\_\_\_
11. \_\_\_\_\_
12. \_\_\_\_\_

**2. Read the instructions. Rewrite the sentences, using the linking expressions then, to begin with, in addition, after that, in conclusion, afterwards.**

*Model: To begin with, you should wet your hands with the water.*

1. \_\_\_\_\_
2. \_\_\_\_\_
3. \_\_\_\_\_
4. \_\_\_\_\_
5. \_\_\_\_\_

## **Lesson 18**

**1. Unscramble the words and write them down.**

*Model: athel – health*

- |                |               |
|----------------|---------------|
| 1. Srexeice –  | 4. Slefylte – |
| 2. Gevetbeal – | 5. Uirtf –    |
| 3. Terwa –     | 6. Oreaicbs – |

**2. Put the words in the brackets into Past Continuous.**

1. My father \_\_\_\_\_ (work) in the garden at 5 yesterday morning.
2. Mark \_\_\_\_\_ (prepare) for the exam from 5 pm till 8 pm yesterday.
3. The police officer \_\_\_\_\_ (investigate) the crime for the entire day last week.
4. My mother \_\_\_\_\_ (cook) dinner when I came home from school.
5. My friends and I \_\_\_\_\_ (skate) when Jack saw us.
6. Yesterday at 6 pm, my family \_\_\_\_\_ (drive) to the nearby city to visit our grandparents.
7. My brother \_\_\_\_\_ (study) when the doorbell rang.
8. Maria \_\_\_\_\_ (sleep) when her alarm-clock went off unexpectedly.
9. Anton \_\_\_\_\_ (jog) in the morning yesterday.
10. My grandparents \_\_\_\_\_ (watch TV) when I called them yesterday.

### 3. Complete the sentences with your own information.

1. At 5 pm, I was preparing for the lesson, when \_\_\_\_\_
2. At the weekend, my brother was doing the physical exercises, when \_\_\_\_\_  
\_\_\_\_\_
3. Last week, I was walking around the city, when \_\_\_\_\_
4. Yesterday, Oksana was cooking dinner, when \_\_\_\_\_
5. They were driving a car for an hour, when \_\_\_\_\_
6. At 7 pm, he was speaking with a friend, when \_\_\_\_\_
7. Yesterday, I was watching TV, when \_\_\_\_\_

## Lesson 19

### 1. Complete the sentences using Past Simple and Past Continuous.

1. What \_\_\_\_\_ (you/do) when I \_\_\_\_\_ (text) you yesterday?
2. They \_\_\_\_\_ (play) football, when Artem \_\_\_\_\_ (hurt) his ankle.
3. Oksana \_\_\_\_\_ (take a bath), when the phone \_\_\_\_\_ (ring).
4. When Artur \_\_\_\_\_ (enter) the room, everyone \_\_\_\_\_ (study).
5. Yesterday, Lida \_\_\_\_\_ (study) in the library, when she \_\_\_\_\_ (meet) her old friend.
6. It \_\_\_\_\_ (be) the first day of summer. The sun \_\_\_\_\_ (shine) brightly and the birds \_\_\_\_\_ (sing) cheerfully.
7. They \_\_\_\_\_ (wait) on the platform, when the train \_\_\_\_\_ (come) to the station.
8. They \_\_\_\_\_ (live) in Portugal, when they \_\_\_\_\_ (be) young.
9. When Marta \_\_\_\_\_ (leave) her house, it \_\_\_\_\_ (rain).
10. Kateryna \_\_\_\_\_ (watch) the movie, when she suddenly \_\_\_\_\_ (hear) some noise from outside.

### 2. Put the given words in the right order to make up sentences.

1. Dinner/ at 6 pm / I / yesterday / cooking / was
- 

2. Cycling / my / were / the / day / friends / entire



**2. Mark the sentences as True (T) or False (F).**

1. \_\_\_\_\_ Listening to loud music can cause problems with hearing.
2. \_\_\_\_\_ Carrots can help to improve the eyesight.
3. \_\_\_\_\_ Cold weather can cause the illnesses.
4. \_\_\_\_\_ Sitting in an uncomfortable position in front of the TV may cause a headache.
5. \_\_\_\_\_ Vitamin C is not good for the human skin.
6. \_\_\_\_\_ Eating fish positively affects human health and activities of the brain.
7. \_\_\_\_\_ Catching a cold is the result of viruses, rather than the cold weather.
8. \_\_\_\_\_ Spending too much time in front of the TV is harmful for your health.
9. \_\_\_\_\_ Carrots are good for protecting the eyesight.
10. \_\_\_\_\_ Eating fish does not influence the level of intelligence.

**Lesson 21**

**1. Your friend wants to become fit. Write 10 recommendations about how he/ she can improve the lifestyle.**

*1. You should start eating more vegetables and fruit, which contain useful vitamins.*

2. \_\_\_\_\_
3. \_\_\_\_\_
4. \_\_\_\_\_
5. \_\_\_\_\_
6. \_\_\_\_\_
7. \_\_\_\_\_
8. \_\_\_\_\_
9. \_\_\_\_\_
10. \_\_\_\_\_

**2. Sort out following food products into two columns.**

*raspberries, French fries, cereals, carrots, burgers, eggs, fried meat, spinach, roasted potatoes, cornflakes, cucumbers, chips, fat pork, grilled vegetables, tomatoes, bacon, pizza, milk, cheese, chocolate, bread*

Healthy food	Unhealthy food

**3. Look at the picture. Say whether the products on the table are healthy or unhealthy.**



*Model: There is some vegetable salad on the table, which is good for your health.*

1. \_\_\_\_\_
2. \_\_\_\_\_
3. \_\_\_\_\_
4. \_\_\_\_\_
5. \_\_\_\_\_
6. \_\_\_\_\_

## **Lesson 22**

### **1. Complete the sentences with the idioms from the list.**

*Bag of bones, back on one's feet, cast iron stomach, picture of health, full of beans, feel blue, fit as a fiddle, clean bill of health*

1. His grandfather had a serious surgical operation, but fortunately he is \_\_\_\_\_ now.
2. Every time when I have to return home from amazing journeys, I \_\_\_\_\_.
3. My little cousin is \_\_\_\_\_. She can play with other children from early morning till night.
4. When we found this cat, it looked like a \_\_\_\_\_. However, our good care and support helped it to return to a good shape again.
5. My friend has never got any problems after tasting the unfamiliar exotic dishes. She really has \_\_\_\_\_.
6. In order to apply to the university, the applicants need to provide many documents, including a \_\_\_\_\_.
7. Many people prefer exercising and jogging in the morning. Not surprisingly, they look \_\_\_\_\_ after such regular activities.
8. My sister regularly works out in the gym and eats exclusively healthy products. She wants to look like a \_\_\_\_\_.

**2. Complete the crossword puzzle.**

1. \_\_\_\_\_ is a regular activity a person tends to perform (for example, jogging, drinking milk, etc.).
2. \_\_\_\_\_ is a useful substance, which is responsible for the muscle growth.
3. \_\_\_\_\_ are useful elements, which are stored in fruit, berries and vegetables.
4. \_\_\_\_\_ is a healthy food for breakfast, which is usually served with milk.
5. \_\_\_\_\_ is a general name of all physical exercises and activities, which help to keep us healthy and fit.
6. \_\_\_\_\_ exercises are important for the human well-being and health.

				<sup>1</sup> h				
<sup>2</sup>				e				
	<sup>3</sup>			a				
<sup>4</sup>				l				
	<sup>5</sup>			t				
			<sup>6</sup>	h				

**Lesson 23**

**1. Match the parts of the sentences.**

1. It was a sunny day,	A. when she suddenly injured her arm.
2. I was walking in the city,	B. and we were wandering a lot.
3. Marta was working out in the gym,	C. when his friend called him to invite to the cinema.
4. My parents were eating pasta,	D. when I noticed the loss of my wallet.
5. Artem was preparing for the exam,	E. and the birds were singing loudly.
6. It was a long journey,	F. I was still cooking the dinner.
7. When the doorbell rang,	G. while their friends were tasting a new dish.



## 2. Fill in the gaps with the correct item.

**There were no tomatoes in Italian food, peanuts in Thai food, or chili peppers in Indian food in the year 1450.**

When you think of Italian food, one of the first things that probably 1) \_\_\_\_\_ to mind is tomato sauce. Thai peanut sauce is recognized around the world, as is the 2) \_\_\_\_\_ of Indian food which comes from chili peppers. Yet when Columbus set forth westward from Europe, none of these things would have been part of the 3) \_\_\_\_\_.

Tomatoes, peanuts and chili peppers are all 4) \_\_\_\_\_ to the Americas and so were unknown in the Old World prior to Columbus' voyages. Tomatoes were originally 5) \_\_\_\_\_ in Peru and spread from there to Mexico. Peanuts were also domesticated in the Amazon, while chili 6) \_\_\_\_\_ appear to have been domesticated separately in both South and Central America. All three were 7) \_\_\_\_\_ crops to many cultures in the New World thousands of years before Europeans had ever heard of them.

Many other important food crops have an American 8) \_\_\_\_\_, including squash, corn, avocado, chocolate, and many 9) \_\_\_\_\_ of beans. Even the so-called "Irish potato" was unknown in Europe before the fifteenth century. It was actually domesticated in the Andean highlands of Bolivia and Peru.

*(25 Amazing Facts about Food. From the editors of NaturalNews.com)*

- |                    |                  |               |                  |
|--------------------|------------------|---------------|------------------|
| 1. A) travels;     | B) enters;       | C) comes;     | D) jumps.        |
| 2. A) spiciness;   | B) hotness;      | C) exotics;   | D) wonder.       |
| 3. A) recipe;      | B) cuisine;      | C) food;      | D) tradition.    |
| 4. A) native;      | B) relative;     | C) dear;      | D) similar.      |
| 5. A) grown;       | B) investigated; | C) planted;   | D) domesticated. |
| 6. A) products;    | B) beans;        | C) peppers;   | D) crops.        |
| 7. A) important;   | B) famous;       | C) favorite;  | D) delicious.    |
| 8. A) lineage;     | B) origin;       | C) heritage;  | D) history.      |
| 9. A) differences; | B) choices;      | C) varieties; | D) diversities.  |

## Lesson 24

### **1. Read the definitions and write down the idioms they describe.**

1. To have feelings of deep sadness or depression –
2. To be in an excellent state of health or physical condition –
3. A report or certificate declaring that the health is satisfactory –
4. An extremely thin person –
5. Able to eat all sorts of food and drink without any indigestion, discomfort or bad effects –
6. Lively, active and healthy –
7. To look extremely healthy –
8. Physically healthy again after an illness or an accident –

### **2. Write antonyms for the words below.**

1. Healthy food – \_\_\_\_\_
2. Slim – \_\_\_\_\_
3. Outdoors – \_\_\_\_\_
4. Fresh food – \_\_\_\_\_
5. Active – \_\_\_\_\_
6. Bad habits – \_\_\_\_\_
7. Regular – \_\_\_\_\_

### **3. Fill in the gaps with was or were.**

1. Oksana and Liza \_\_\_\_\_ watching TV yesterday at 4 pm.
2. My family \_\_\_\_\_ eating together last week in the evening.
3. The police \_\_\_\_\_ investigating the crime last week.
4. I \_\_\_\_\_ trying to convince my parents to go to the seaside yesterday.
5. His grandparents \_\_\_\_\_ living in Paris twenty years ago.
6. The musicians \_\_\_\_\_ playing my favourite song at the restaurant yesterday.
7. My mother \_\_\_\_\_ cooking the roasted meat at 5 pm.

## Lesson 25

**1. Find the mistakes in the following sentences and correct them.**

1. Artur were preparing for the exam yesterday.
2. She was jogging in the morning, when she had met her friend.
3. The train will leave at 12:45 from the main railway station.
4. I visit my grandmother next week after passing my exams.
5. You might not eat too much fatty food, because it is not good for your health.
6. My father worked in the garden at 5 p.m. yesterday.
7. He was preparing his homework, while his brother watched TV.
8. You should eat more junk food, as it helps to improve your health.
9. There wasn't nobody in the room.
10. I do not like to eat many chocolate at once.

**2. Circle the examples of healthy habits from the list.**

- Jogging;
- Eating junk food;
- Watching TV for a long time;
- Eating many vegetables;
- Drinking plenty of fresh water;
- Working out in the gym;
- Spending time in front of the screen;
- Playing video games;
- Avoiding fatty food;
- Drinking a lot of soda water;
- Consuming many fruit and berries;
- Doing physical exercises;
- Skipping breakfasts;
- Wearing warm cloths;
- Spending time outdoors;
- Sleeping enough.

# Unit 3. AT THE LIBRARY. READING BOOKS

## Lesson 26

1. Look at the picture of a book. Label the numbers.

1. \_\_\_\_\_
2. \_\_\_\_\_
3. \_\_\_\_\_
4. \_\_\_\_\_
5. \_\_\_\_\_
6. \_\_\_\_\_
7. \_\_\_\_\_
8. \_\_\_\_\_
9. \_\_\_\_\_
10. \_\_\_\_\_

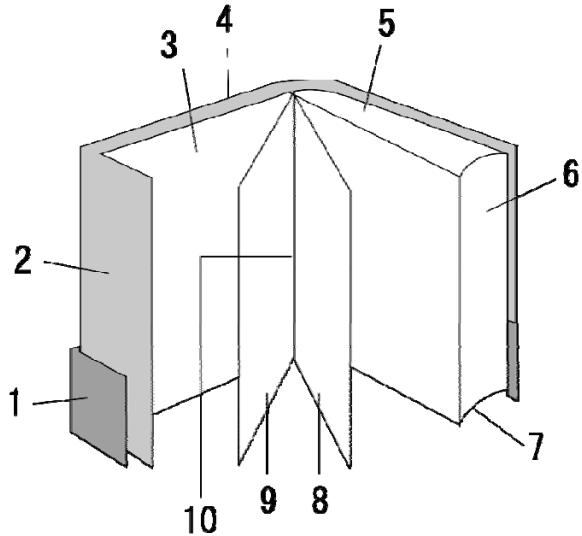

2. Look at the plan of the architecture library. Say where different areas are situated.

*Model: The book drop area is situated immediately to the right of the entrance.  
 Audio-visual area is situated between the archives and staff workroom.*

### ARCHITECTURE LIBRARY

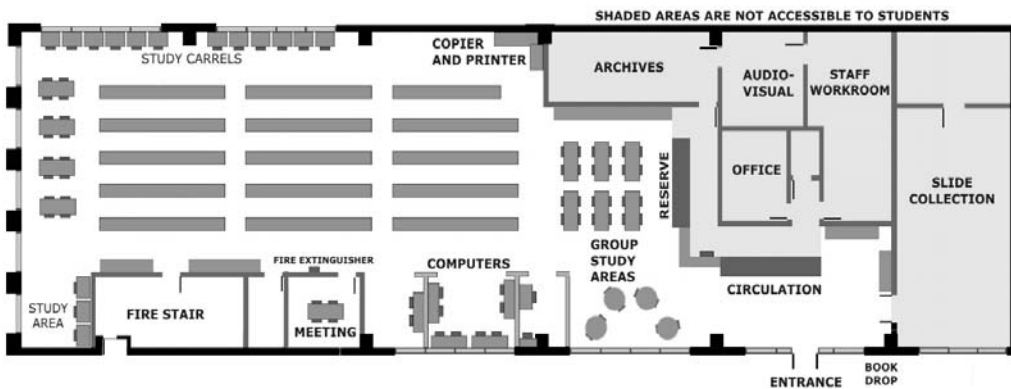

NORTH ATRIUM - SMITH ARCHITECTURE BUILDING

1. The copier and printer \_\_\_\_\_
2. The slide collection \_\_\_\_\_
3. The fire stair \_\_\_\_\_
4. The study area \_\_\_\_\_
5. The group study areas \_\_\_\_\_
6. The computers \_\_\_\_\_
7. The meeting point \_\_\_\_\_
8. The archives \_\_\_\_\_
9. The staff workroom \_\_\_\_\_
10. The study carrels \_\_\_\_\_

## Lesson 27

### 1. Fill in the gaps with the correct words from the box below.

*attend cover in the due time*  
*inform violations fold*  
*turn a book upon its clear face*

1. When you take a book from a library, you need to return it \_\_\_\_\_ . Otherwise you will have to pay a penalty.
2. Those students, who \_\_\_\_\_ all classes during the year, have better chances to pass the exams.
3. One should not judge the book by its \_\_\_\_\_. It is important to pay attention to the content.
4. The visitors of the library shouldn't \_\_\_\_\_. In other case, they will have to compensate the price of the book.
5. The \_\_\_\_\_ of the traffic rules may lead to serious accidents.
6. My travel suitcase is very small, so I need to learn how to \_\_\_\_\_ my clothes effectively.
7. The administrator should \_\_\_\_\_ about the changes in the schedule of working hours in advance.

**2. Read the text and correct the mistakes in the statements given below.**

**The Benefits and Advantages of e-Books**

(By Remez Sasson)

An e-book is a book in electronic format. It is downloaded to a computer, PC, Mac, laptop, PDA, tablet, smartphone or any other kind of reading device, and is read on the screen. It can have numbered pages, table of contents, pictures and graphics, exactly like a printed book.

E-books present many benefits and advantages, and this article shows some of them. It is very simple and easy to purchase and download e-books through the Internet. It is exactly like purchasing any other product. All you have to do is click on the link and the e-book will automatically download to your computer.

E-books are delivered almost instantaneously. You can purchase, download and start reading them within minutes, without leaving your chair. You don't have to go to a bookstore to buy them, neither wait for them for days, weeks and sometimes more to arrive in the mail.

No trees are required to manufacture paper for the pages of e-books. When you need certain information, you can get it immediately, by downloading an e-book. E-books take up less space. You practically don't need any space to store them. You don't need a library or a room for them. You can store hundreds and thousands of e-books on your computer or reading device.

People are already spending a lot of time in front of their computers, so why not read an e-book, instead of doing something else?

**Statements**

1. The e-books can be downloaded only to your computer or laptop. \_\_\_\_\_

2. The production of e-books is harmful for the environment. \_\_\_\_\_

3. The process of buying e-books is very difficult and continuous. \_\_\_\_\_

4. You need to wait for a long time to get your e-book. \_\_\_\_\_

5. E-books demand plenty of space for storage. \_\_\_\_\_

6. You can store only a few e-books on your electronic devices at the same time.

**3. Write down the advantages of using e-books. Use the previous exercise to get ideas.**

1. \_\_\_\_\_
2. \_\_\_\_\_
3. \_\_\_\_\_
4. \_\_\_\_\_
5. \_\_\_\_\_

## Lesson 28

**1. Put the verbs in brackets into the correct form in the Passive Voice.**

1. German \_\_\_\_\_ in many countries (speak).
2. The car \_\_\_\_\_ by the engineer now (repair).
3. The house \_\_\_\_\_ every day (clean).
4. Many instruments \_\_\_\_\_ out of plastics (produce).
5. I \_\_\_\_\_ to the school by my mother (drive).
6. The animals in the zoos \_\_\_\_\_ every morning (feed).
7. The store \_\_\_\_\_ by the administrator (open and close).
8. Paper \_\_\_\_\_ of wood (make).
9. The parliament \_\_\_\_\_ by the people (elect).
10. When I have health problems, I \_\_\_\_\_ to the hospital regularly (take).

**2. Choose the words for the definitions below.**

*Magazine, encyclopedia, library clerk, media section, online catalogue, CD (compact disc), newspaper, reference desk, microfilm, videocassette*

1. A publication, usually issued daily or weekly, containing current news, editorials, feature articles, and usually advertising \_\_\_\_\_

2. A film on which printed materials are photographed at a reduced size \_\_\_\_\_
3. A cassette containing a videotape \_\_\_\_\_
4. A place, where professional librarians provide library users with direction to library materials \_\_\_\_\_
5. A type of reference work, holding a summary of information from either all branches of knowledge or a particular branch of knowledge \_\_\_\_\_
6. A periodical containing a collection of articles, stories, pictures, or other features \_\_\_\_\_
7. A small optical disc on which data such as music, text, or graphic images is digitally encoded \_\_\_\_\_
8. A place in the library, where the digital materials (audio, video, CDs, etc.) are stored \_\_\_\_\_
9. An online register of all bibliographic items found in a library \_\_\_\_\_
10. A person, working in a library \_\_\_\_\_.

**3. Fill in the gaps with the words from the previous exercise.**

1. I really like to work with the personnel at this library. The \_\_\_\_\_ are always very sociable, approachable and competent.
2. Our school library has a big \_\_\_\_\_, where the visitors can use computers and get the information in a digital format.
3. Lida is working over the research, for which she needs to collect the \_\_\_\_\_ from the previous decade.
4. This library has introduced the \_\_\_\_\_, where the visitors can find the names of the authors and books before actually visiting it.
5. Nowadays, the \_\_\_\_\_ are not widely used, though some years ago they helped to store great amounts of information.
6. As a rule, the \_\_\_\_\_ is situated near the main entrance, so that the visitors can easily get the needed information from the professional workers.



## Lesson 29

**1. Use the prompts to write down the names of your favourite books.**

*Model: My favourite romance is "Tess of the D'urbervilles", written by Th. Hardy*

1. My favourite adventure novel is \_\_\_\_\_
2. My favourite romance is \_\_\_\_\_
3. My favourite historical novel is \_\_\_\_\_
4. My favourite detective story is \_\_\_\_\_
5. My favourite poem is \_\_\_\_\_
6. My favourite science fiction novel is \_\_\_\_\_
7. My favourite play is \_\_\_\_\_

**2. Mark the sentences which are written in the Passive Voice. Then find the sentences in the Active Voice and rewrite them into the Passive Voice.**

The post is brought every day	The teachers collect books after each lesson	Olena does her homework every day
Apples are picked in autumn	The patients are visited by their relatives every afternoon	Parents tell their children to be quiet
Books are kept in the bookcase	Fishermen catch fish in the sea	The coach asks Peter to run in the race

---

---

---

---

---

---

---

---

---

---

## Lesson 30

### 1. Match the words with their definitions.

1. Stimulating	A. attracting and holding the attention or interest;
2. Vigorous	B. always active or changing;
3. Forceful	C. making (a person) excited or interested in something;
4. Dynamic	D. expressed in a way that is effective and that influences people's thoughts and ideas;
5. Gripping	E. powerful in action or effect;
6. Captivating	F. holding the attention or interest intensely.

### 2. Read the sentences. Replace the underlined words with their synonyms from the exercise above.

1. The performance at the theatre was so attractive that the audience did not want it to end.

2. The tricks of the street performers and musicians were so fascinating that they managed to gather a really big audience around.

3. Artem can visit several new cities this weekend. He really likes active holidays.

4. He gave him a lively handshake and introduced himself.

5. This book has made a strong effect on my outlook and ideas.

6. My friends say that parachute jumping is a thrilling activity, though I think it can be quite dangerous.

### 3. Write passive sentences in Present Simple.

*Model: The window/ close/ parents: The window is closed by parents.*

1. The documents/ print/ office clerks. \_\_\_\_\_

2. The letter / send/ pen friend. \_\_\_\_\_

3. The food/ not eat/ a little child. \_\_\_\_\_

4. The book / not read/ Marta. \_\_\_\_\_

5. The shoes / buy / my mother. \_\_\_\_\_

6. The shop/ open/ shop assistant. \_\_\_\_\_
7. The house/ design/ architects. \_\_\_\_\_
8. The dinner/ cook/ grandmother. \_\_\_\_\_
9. The litter/ thrown away. \_\_\_\_\_
10. The car/ wash/ I. \_\_\_\_\_

## Lesson 31

### 1. Complete the dialogue "At the Library".

Library assistant: Good morning! Can I help you?

You: \_\_\_\_\_

Library assistant: Which literature genres do you prefer?

You: \_\_\_\_\_

Library assistant: Would you prefer printed books or e-books?

You: \_\_\_\_\_

Library assistant: You can look for the books in the area right in front of the media section. For how much time would you like to take a book?

You: \_\_\_\_\_

Library assistant: All right. You can take a book now. In a fortnight, please, bring a book back and leave it at the checkout desk. Have a nice day!

You: \_\_\_\_\_

### 2. Find out and write down the names of the authors of the following books.

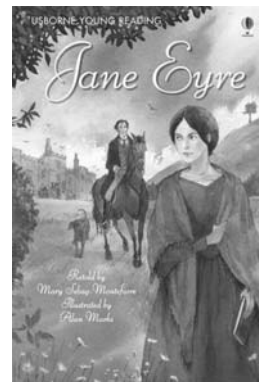
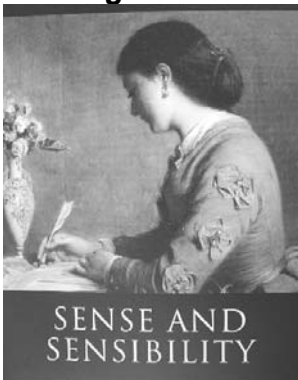

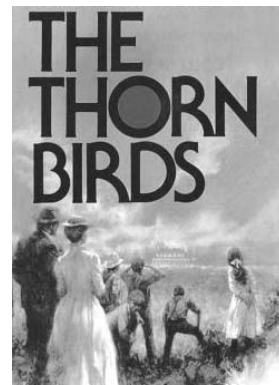
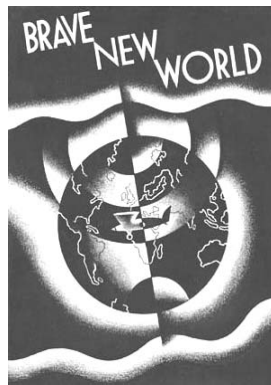

## Lesson 32

**1. Read at the words below. Which words will you use to describe the adventure novel? A romance? A science fiction? Write down the words into columns. One and the same word can be used more than once.**

*Stimulating, tear-jerker, holding, captivating, vigorous, gripping, dynamic, happy-end, enchanting, forceful, sentimental, dramatic, tragic, fascinating, energetic, powerful, nostalgic, exciting.*

Adventure Novel	Romance	Science Fiction

**2. Put the questions to the underlined words in the sentences below.**

*Model: The books are bought by me. – What is bought by me?*

1. The net is filled with the fish.

---

2. The house is constructed by the builders.

---

3. The fruit are planted in the garden.

---

4. The patients are visited today.

---

5. The wall is painted in white.

---

6. The film is operated by the professional director.

---

7. The task is completed by my classmate.

---

### **Lesson 33**

**1. Put the words in the right order to make up sentences.**

1. cows/ by/ milk/ the/ produced/ is:

---

2. served/ meal/ is/ the/ times/ day/ three/ a:

---

3. hotel/ spoken/ German/ is/ that/ in:

---

4. morning/ flowers/ watered/ the/ are/ every:

---

5. cat/ the/ are/ sausages/ stolen/ are/ by:

---

6. this/ books/ are/ shop/ the/ sold out/ in:

---

7. father's/ we/ amused/ are/ his/ by/ stories:

---

8. shakespeare/ this/ written/ book/ is/ by:

---

9. famous/ these/ are/ photographer/ pictures/ made/ a/ by:

---

10. garden/ apple trees/ planted/ are/ the/ in:

---

## **2. Choose the right word to complete the sentences.**

1. Olena went to the school library to \_\_\_\_\_ (check in/ check out) some information about the British literature of the 19<sup>th</sup> century.

2. It is impossible to \_\_\_\_\_ (access/ find) the online catalogue of this library without registering a personal account.

3. The \_\_\_\_\_ (romances/ myths) of the ancient Greece tell us a lot about its lifestyle, culture, beliefs and traditions.

4. This ring is very \_\_\_\_\_ (valuable/ expensive) for me, as it is a gift from my grandmother.

5. It is better to avoid food, which \_\_\_\_\_ (keeps/ contains) a lot of fats and sugar.

6. The sports coaches apply to many methods to \_\_\_\_\_ (strengthen/ encourage) the athletes to do their best during the competitions.

7. In this part of the country heavy rains are \_\_\_\_\_ (rare/ important) occasions.

8. Initially, the folk stories and legends \_\_\_\_\_ (existed/ survived) only in the oral form.

## Lesson 34

### 1. Read the text and choose the word to fill in the gaps.

#### The Biggest Libraries in the World

##### Library of Congress

If you've already watched the movie National Treasure 2, then you've already taken a glimpse of this 1) \_\_\_\_\_ library. Within the confines of this centre, you'll find all you need to answer your questions about culture, science, philosophy, history, and any other 2) \_\_\_\_\_.

During the War of 1812, a huge portion of the original 3) \_\_\_\_\_ was sold. Fortunately, another 6,457 books were sold to the library by Thomas Jefferson from his very own collection. Composed of four 4) \_\_\_\_\_ in Washington, D.C., the Library of Congress is such an impressive display of books and a grandly designed structure that it has been used in 5) \_\_\_\_\_ movies to this date. With a vast book collection at over 30 million and written in just about any language you can think of, the Library of Congress definitely deserves all the fame. The public can visit the library, but only high ranking American officials are allowed to check out books.

##### Harvard University Library

Compared to all the other universities in the world, Harvard University Library houses the most 6) \_\_\_\_\_ private collection of books. Established in the year 1638, the Harvard library is considered as America's 7) \_\_\_\_\_ one. John Harvard was the first to 8) \_\_\_\_\_ books to this great collection, which was initially composed of just 400 books. As the years went by, the collection grew to large 9) \_\_\_\_\_ and keeps on doing so to this day. In the year 1638, the Harvard University Library housed the United States' most impressive collection of books, but a disastrous fire destroyed that status as it turned a considerable number of books into 10) \_\_\_\_\_.

*(by Staff Writers)*

- |                  |                 |                |                 |
|------------------|-----------------|----------------|-----------------|
| 1. A) important; | B) magnificent; | C) vigorous;   | D) huge.        |
| 2. A) subjects;  | B) questions;   | C) ideas;      | D) chapters.    |
| 3. A) number;    | B) books;       | C) amount;     | D) collection.  |
| 4. A) areas;     | B) buildings;   | C) regions;    | D) territories. |
| 5. A) some;      | B) endless;     | C) continuous; | D) numerous.    |
| 6. A) enormous;  | B) interesting; | C) diverse;    | D) original.    |
| 7. A) initial;   | B) oldest;      | C) primary;    | D) ancient.     |
| 8. A) place;     | B) add;         | C) remove;     | D) reveal.      |
| 9. A) portions;  | B) scales;      | C) sizes;      | D) proportions. |
| 10. A) nothing;  | B) sand;        | C) ashes;      | D) ground.      |

**2. Correct the following sentences, using the information from the previous exercise.**

*Model: The Library of Congress is the second biggest library in the world –  
The Library of Congress is the biggest library in the world.*

1. The Library of Congress has appeared in few American movies. \_\_\_\_\_  
\_\_\_\_\_
2. Everyone can use the books, stored in the Library of Congress. \_\_\_\_\_  
\_\_\_\_\_
3. The Library of Congress contains books, written exclusively in the English language. \_\_\_\_\_  
\_\_\_\_\_
4. Harvard University Library has been founded in the 18<sup>th</sup> century. \_\_\_\_\_  
\_\_\_\_\_
5. Some books of Harvard University Library have been stolen by the thieves.  
\_\_\_\_\_  
\_\_\_\_\_
6. Harvard University Library has always comprised of huge book collections.  
\_\_\_\_\_  
\_\_\_\_\_



**3. Rewrite the following sentences in the Active Voice.**

1. The car is stolen by the thieves. \_\_\_\_\_  
\_\_\_\_\_
2. The sky is covered with the grey clouds. \_\_\_\_\_  
\_\_\_\_\_
3. The dog is adopted by a family from France. \_\_\_\_\_  
\_\_\_\_\_
4. The papers are printed by the office workers. \_\_\_\_\_  
\_\_\_\_\_
5. The homework is completed by a student. \_\_\_\_\_  
\_\_\_\_\_
6. The trees are chopped down by a private company. \_\_\_\_\_  
\_\_\_\_\_
7. The window is closed by a strong wind. \_\_\_\_\_  
\_\_\_\_\_
8. The information is announced by the news reporters. \_\_\_\_\_  
\_\_\_\_\_

**Lesson 35**

**1. Find the names of Shakespeare's plays by combining the words from columns A and B.**

<input type="checkbox"/> Merchant of	A. Night
<input type="checkbox"/> Romeo	B. Verona
<input type="checkbox"/> Twelfth	C. Venice
<input type="checkbox"/> King	D. And Juliet
<input type="checkbox"/> Antony	E. Night's Dream
<input type="checkbox"/> Midsummer	F. Errors
<input type="checkbox"/> Two Gentlemen of	G. Lear
<input type="checkbox"/> Comedy of	H. and Cleopatra

**2. Mark the statements as true (T) or false (F). Correct the false ones.**

1. \_\_\_\_\_ William Shakespeare was born in 1564 in London.
2. \_\_\_\_\_ W. Shakespeare was born in a very poor family.
3. \_\_\_\_\_ W. Shakespeare learnt Latin at Stratford Grammar School.
4. \_\_\_\_\_ Shakespeare married Anna Hathaway at the age of 30.
5. \_\_\_\_\_ William and Anna had no children.
6. \_\_\_\_\_ W. Shakespeare founded his theatre in London.
7. \_\_\_\_\_ W. Shakespeare wrote more than a hundred poems.
8. \_\_\_\_\_ W. Shakespeare died at the age of 52 in London.

**3. Correct the mistakes in the following sentences.**

1. The cake is buyed by Lida.

*The cake is bought by Lida.*

2. Montenegro are visited by millions of tourists annually. \_\_\_\_\_

- 
3. This amazing picture is painted with Andrii. \_\_\_\_\_

- 
4. The living room is clean by Sofia. \_\_\_\_\_

- 
5. The fireworks is adored by both children and adults. \_\_\_\_\_

- 
6. The glass is maked out of sand. \_\_\_\_\_

- 
7. Two cats are rescued with Artur. \_\_\_\_\_

- 
8. The plate is filled by cherries. \_\_\_\_\_

- 
9. The company is own by a government. \_\_\_\_\_

- 
10. The jewelry is stealed by a group of criminals.

---

**Lesson 36 (Optional)**

## Unit IV. SCHOOL LIFE

### Lesson 37

**1. Find the names of school subjects by pitting the letters in the right order.**

*Model: s h a m t – maths*

1. i y h t s o r –
2. h i e n g l s –
3. y o e h g r g p a –
4. h m s y r t c e i –
5. s c i p h s y –
6. s c u i m –
7. l g y i o b o –

**2. Study at Jane's school schedule and answer the questions.**

	Monday	Tuesday	Wednesday	Thursday	Friday
1.	Biology	Chemistry	Arts	French	History
2.	English	Maths	Physics	Information Technologies	English
3.	Geography	English	Geography	Maths	Arts
4.	English Literature	French	English	Social Sciences	Chemistry
5.	Music	History	Physical education	English Literature	Geography
6.	Physical Education		World history	Music	

1. On which days does Jane have 6 lessons? \_\_\_\_\_
2. How many times a week does she study English? \_\_\_\_\_
3. What is the third subject on Friday? \_\_\_\_\_
4. Does Jane study Information Technologies? When? \_\_\_\_\_
5. On which days does Jane have Physical Education? \_\_\_\_\_
6. How often does Jane study French? \_\_\_\_\_
7. Which subjects are taught more than twice per week? \_\_\_\_\_
8. Which subject is taught only once a week? \_\_\_\_\_

**3. Complete the table with the missing stages of the education in Great Britain.**

Play group or _____
Primary school
_____
Higher School
_____
_____

**Lesson 38**

**1. Rewrite the sentences in the Future Simple tense form.**

*Model: The book is sold out. – The book will be sold out*

1. A new laptop is bought by Mark. – \_\_\_\_\_
2. The contract is signed by the boss. – \_\_\_\_\_
3. A new movie is not shown. – \_\_\_\_\_
4. A new worker is employed by the organization. – \_\_\_\_\_
5. The bath tub is repaired by the plumber. – \_\_\_\_\_
6. The castle is visited by hundreds of tourists. – \_\_\_\_\_
7. A new door is painted into green. – \_\_\_\_\_
8. The window is opened after the rain. – \_\_\_\_\_

**2. Mark statements as true (T) or false (F). Correct the false ones.**

1. \_\_\_\_\_ In Great Britain, compulsory education is free of charge.
2. \_\_\_\_\_ The education in Britain is obligatory for all children aged 4-15.
3. \_\_\_\_\_ More than 90% of pupils in England receive public funds.
4. \_\_\_\_\_ The curriculum in different state schools may vary.

5. \_\_\_\_\_ In Great Britain, the teachers at schools are addressed by their first names.
6. \_\_\_\_\_ In England, there are two academic terms per year.
7. \_\_\_\_\_ The school starts in September and ends in summer.
8. \_\_\_\_\_ School uniform is not obligatory at schools of Great Britain.
9. \_\_\_\_\_ Both boys and girls should wear trousers as a part of the school uniform.
10. \_\_\_\_\_ The school lessons are held during all days of the week.

**3. Circle the odd word out. Explain your choice.**

1. Chemistry – Biology – Literature – Physics.
2. Music – Arts – Literature – Geography.
3. Primary school – secondary school – play ground – higher school.
4. Schedule – curriculum – timetable – vacations.
5. Public schools – universities – state schools – private schools.

## Lesson 39

**1. Look at the plan of the theatre, which will be built in the near future. Discuss the location of its different parts.**

*Model: The stalls will be situated right in front of the stage, before the amphitheatre.*

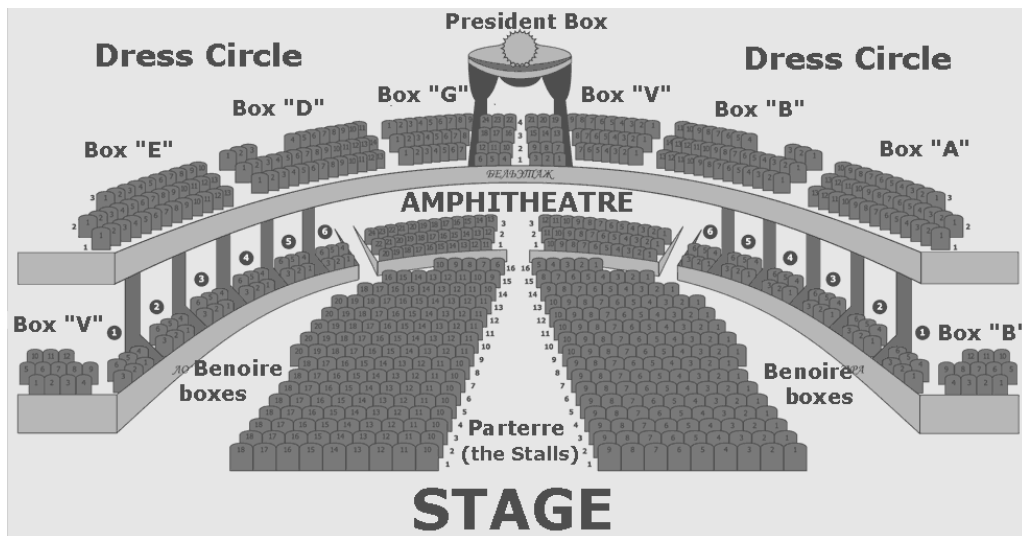

1. \_\_\_\_\_
2. \_\_\_\_\_
3. \_\_\_\_\_
4. \_\_\_\_\_
5. \_\_\_\_\_

**2. State which school objects do you use in the following situations.**

*Model: writing a test – a sheet of paper, a pen, a pencil and an eraser*

1. Making a video presentation – \_\_\_\_\_
2. Doing the exercises – \_\_\_\_\_
3. Listening to the teacher's explanations – \_\_\_\_\_
4. Writing on the blackboard – \_\_\_\_\_
5. Acting out a dialogue – \_\_\_\_\_
6. Listening to the audio records – \_\_\_\_\_

### Lesson 40

**1. Complete the table to compare the system of education in Great Britain, Japan and Ukraine.**

Schooling	Great Britain	Japan	Ukraine
Period of studies		In Japan, pupils study 240 days per year.	
The beginning of the schoolyear	In Great Britain, children start school studies in September.		
Homework		In Japan, children spend 3 hours on weekends to do their homework.	
After-school activities			Children in Ukraine like to do sports activities after classes.
The end of the school-year			

Leisure time			
Amount of children in the classes			

**2. Answer the questions, using the verbs in the Passive Voice in the Future Simple tense form.**

*Model: Where will the benches be placed? (garden): The benches will be placed in the garden.*

1. What will be cooked for dinner? (pasta):

---

2. When will the papers be printed out? (Wednesday):

---

3. Where will the house be built? (between the theatre and the supermarket):

---

4. Who will the book be taken by? (my sister):

---

5. When will the car be sold? (in two weeks):

---

6. Where will the bus be parked? (at the station):

---

7. What will the basket be filled with? (berries):

---

8. What will be announced on the following meeting? (the report):

---

9. When will the products be stored in the fridge? (in five minutes):

---

10. Where will the garden be located? (in front of the main entrance):

---

11. What will be carried in the bag? (the clothes):

---

12. When will the money be transferred to another account? (Monday):

---

## Lesson 41

**1. Decide which school facilities should be used perform the following activities. Complete the table with the expressions below.**

Playing volleyball, watching a documentary film, swimming, doing physical exercises, chatting with the friends, playing water polo, surfing the Internet, participating in the sports competitions, preparing the homework, playing board games, playing football, practicing aqua aerobics, listening to the audio records.

Sports stadium	Swimming pool	Playground	Audio-visual centre

**2. Look at the picture below and name the activities. State which of them you can perform at your school.**

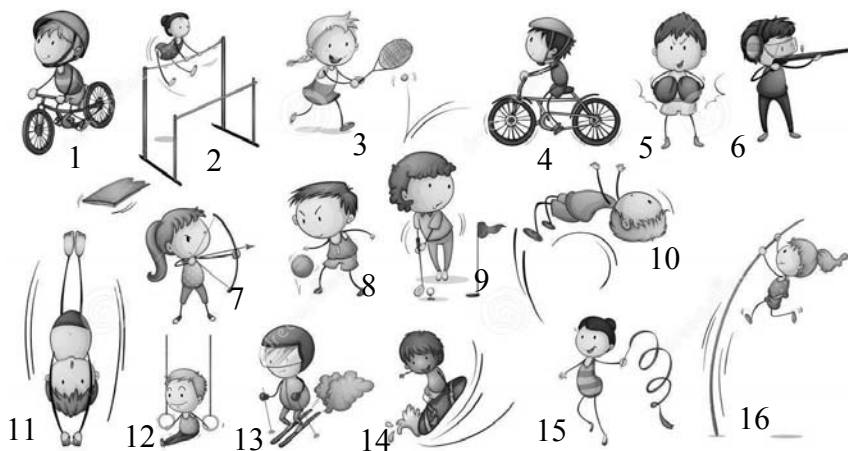

1		5		9		13	
2		6		10		14	
3		7		11		15	
4		8		12		16	



## Lesson 42

**1. Find the names of the school items (technology, objects or rooms) in the box letters given below.**

r	c	d	r	o	n	v	c	t	a
l	a	b	f	r	b	o	o	k	p
w	f	g	d	c	j	n	m	l	e
a	e	r	p	o	o	l	p	v	n
u	t	f	e	n	z	d	u	i	c
d	e	s	k	c	m	x	t	i	i
i	r	s	y	e	o	l	e	n	l
o	i	w	e	r	d	k	r	l	f
t	a	z	s	t	a	d	i	u	m
p	l	a	y	g	r	o	u	n	d

**2. Write down the school objects and technologies, that could be found in the following school rooms.**

Reading room	Desks, books, magazines, newspapers, references, encyclopedias, lamps, pens, pencils, copybooks...
Library	
Canteen	
Sports stadium	
Concert hall	
Swimming pool	
Classroom	
Computer laboratory	

**3. Guess the words by their definitions.**

An instrument for writing or drawing with ink _____	A piece of furniture with a flat top for writing _____	A small bar or cafeteria at schools or universities _____
A place, where book collections are kept _____	A large, usually open structure for sports events _____	A dark-coloured panel for writing on with chalk _____

## Lesson 43

### 1. Match the idioms with their definitions.

1. A cow college	a. To count a number of people
2. To count noses	b. To read a book
3. To take the roll	c. A school or institution, where agriculture is studied
4. A teacher's pet	d. To call the names of the students to check whether they are present
5. To have one's nose a book	e. A teacher's favorite pupil or student

### 2. Complete the sentences with the idioms from the previous exercise.

1. When Lida was preparing for her exam, she had \_\_\_\_\_ during the entire week.

2. Some teachers do not check the attendance of the students, though some never start a lesson without \_\_\_\_\_.

3. My brother would like to continue studying at \_\_\_\_\_, as he loves nature, gardening and agriculture.

4. The library assistant decided to \_\_\_\_\_ and then write down the names of the visitors in a reference book.

5. Artur gets only good marks and participates in the civil life of the school, as well. Not surprisingly, he is a \_\_\_\_\_.

## Lesson 44

### 1. Put the words in the brackets into the Active or Passive Voice in Future Simple.

1. The school \_\_\_\_\_ (close) during the summer holidays.

2. The school \_\_\_\_\_ (accept) a hundred new students next year.

3. The letters \_\_\_\_\_ (send) to our friends within two weeks.

4. The letters \_\_\_\_\_ (contain) all the needed information about the summer camp.

5. A new book of this author \_\_\_\_\_ (tell) the readers about new adventures of the main character.
6. His new book \_\_\_\_\_ (publish) next year.
7. The theatre \_\_\_\_\_ (not work) for a few months because of the renovation.
8. A new theatre \_\_\_\_\_ (build) on the place of the former museum.
9. The entrance tickets \_\_\_\_\_ (give) to us after the reservation.
10. The tickets \_\_\_\_\_ (be) more expensive before the performance, so it is better to buy them in advance.

**2. Rewrite the sentences in Future Simple.**

1. The computer is used every Sunday. – \_\_\_\_\_
2. The work is done by his assistant. – \_\_\_\_\_
3. The flowers are planted in this garden. – \_\_\_\_\_
4. A new book is sold out nearly immediately. – \_\_\_\_\_
5. The tickets are booked via the Internet. – \_\_\_\_\_
6. I am given a good advice by my teacher. – \_\_\_\_\_
7. The vase with water is refilled every morning. – \_\_\_\_\_
8. The paper is torn by his careless movement. – \_\_\_\_\_
9. The shop is closed after 8 pm. – \_\_\_\_\_
10. The vacations are spent at the countryside. – \_\_\_\_\_

**Lesson 45**

**1. Make up a mind-map for the word "education". Write as many associations as possible.**

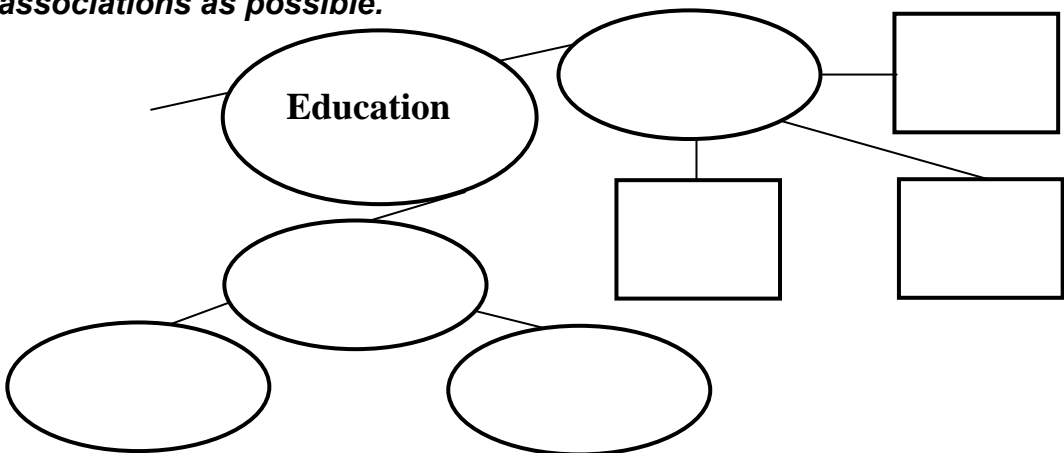

**2. Fill in the gaps with the words from the box below.**

<i>interactive whiteboard</i>	<i>well-equipped</i>	<i>variety</i>
<i>overhead projector</i>	<i>playground</i>	<i>event</i>

1. Our school stadium is really \_\_\_\_\_, because it has many facilities for different games and physical activities.
2. This classroom is equipped with the \_\_\_\_\_, so that the children do no need to use the chalk for writing on it anymore.
3. All kindergartens have a good \_\_\_\_\_, where children can spend time together and play different games.
4. My school will organize a big sporting \_\_\_\_\_, and many pupils will participate in it.
5. The youth club offers a \_\_\_\_\_ of different sport, art and leisure activities to its visitors.
6. If you want to demonstrate a PowerPoint presentation, do not forget to turn on the \_\_\_\_\_.

**3. Choose the correct answer to fill in the gaps.**

1. The train \_\_\_\_\_ at 5 pm.  
A. will leave;      B. leaves;      C. left;      D. is leaving.
2. You \_\_\_\_\_ come on time for the classes.  
A. may;      B. could;      C. should;      D. must.
3. He will be \_\_\_\_\_ to fix the mistakes after revising the test.  
A. asked;      B. ask;      C. have asked;      D. asking.
4. I \_\_\_\_\_ for the vacations in three days.  
A. leave;      B. am leaving;      C. will leave;      D. leaves.
5. The post \_\_\_\_\_ next Friday.  
A. is delivered;      B. delivers;      C. delivering;      D. will be delivered
6. Lucy is a teacher's \_\_\_\_\_, because she always submits the papers in time.  
A. cat;      B. dog;      C. pet;      D. pupil.
7. Is there \_\_\_\_\_ who speaks French in this room?  
A. anyone;      B. someone;      C. no one;      D. anything.

8. You should check the \_\_\_\_\_ catalogue, before going to the library.  
 A. distant;                    B. electric;                    C. online;                    D. removed.
9. At what time \_\_\_\_\_ the plane \_\_\_\_\_?  
 A. does/leave;                    B. does/leaves;                    C. will/leave                    D. will/left.
10. They \_\_\_\_\_ an address to where the parcel should be delivered.  
 A. will be given;                    B. will be giving;                    C. will be given;                    D. is given.

## Lesson 46

### 1. Turn the sentences into the Passive Voice.

Model: Mercedes cars/ Germany/ make – *Mercedes cars are made in Germany.*

1. Pasta/ boiling water / cooked –

---

2. Children / schools/ teach –

---

3. Volleyball / many countries/ play –

---

4. Peaches / warm countries/ plant –

---

5. Performance / first time / show –

---

6. House/ construct/ builders –

---

7. Homework/ Olena / do –

---

8. Fish / cat / eat –

---

9. Candles / matches / lit –

---

10. Plate / fruit / fill –

---

**2. Answer the questions, using the negative sentences.**

*Model: Will the flowers be bought? – No, the flowers won't be bought.*

1. Will the housework be done by the mother?

---

2. Are the parcels delivered on time?

---

3. Will the laptop be repaired till the weekend?

---

4. Will the money be transferred to the bank soon?

---

5. Are the books stored in the shop?

---

6. Is this car powered with the electricity?

---

7. Will the cakes be eaten on Friday?

---

8. Will the cloths be ironed before our departure?

---

9. Will the battery be charged by you?

---

10. Is the design of this house planned by an architect?

---

**Lesson 47**

**1. Choose the best option to fill in the gaps.**

1. You need to study well to \_\_\_\_\_ the exams.

A. pass;

B. write.

2. It is much easier to write on the \_\_\_\_\_ whiteboard in comparison with

the traditional blackboard.

A. electronic;

B. interactive.

3. Can \_\_\_\_\_ help me to clean the classroom after the lessons?

A. anybody;

B. somebody.

4. When will the presentation be \_\_\_\_\_?  
A. shown; B. showing.
5. He \_\_\_\_\_ the opera theatre on the weekend.  
A. is visiting; B. visits.
6. Should I leave the library books at the \_\_\_\_\_ desk in a fortnight?  
A. check-in; B. check-out.
7. I would like to stay \_\_\_\_\_ close to the downtown.  
A. somewhere; B. anywhere.
8. Is this box \_\_\_\_\_ with the nuts or berries?  
A. filled; B. felt.
9. Some of my friends are studying at \_\_\_\_\_ college.  
A. animal; B. cow.
10. Is there \_\_\_\_\_ to eat in our fridge?  
A. anything; B. something.

**2. Correct the mistakes in the sentences given below.**

1. At what time will be the shop closed on the weekend?

---

2. The car won't driven without the petrol.

---

3. The road will be reconstructing in the near future.

---

4. The sun will be seen not because of the dark clouds.

---

5. Probably, we will be visited the castle on our way back from the excursion.

---

6. The chocolate will be buyed at the local shop.

---

7. The pictures will taken from the top.

---

8. The mistakes will be fix after the thorough revision.

---

**3. Describe the actions shown in the pictures, using the Passive Voice:**



*The tree is planted.*

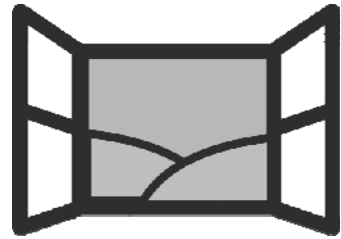

## Lesson 48

**1. Read the annotations of the books and fill in the gaps with the suitable words.**

1. William Golding's compelling story "The Lord of the Flies" about a group of very ordinary small boys on a coral 1) \_\_\_\_\_ has become a modern classic. As ordinary 2) \_\_\_\_\_ of behaviour collapse, the whole world the boys know collapses with them — the world of cricket and homework and schooling — and another world is revealed beneath full of new experience and new 3) \_\_\_\_\_.

2. Jane Austen's "Emma" is a book about a beautiful, clever, rich and single Emma Woodhouse, who is perfectly content with her 4) \_\_\_\_\_ and sees no need for either love or marriage. Nothing, however, delights her more than interfering in the romantic 5) \_\_\_\_\_ of others. But when she ignores the warnings of her good 6) \_\_\_\_\_ Mr. Knightley and attempts to arrange a suitable match for her



protegee Harriet Smith, her carefully laid plans soon unravel and have consequences that she never 6) \_\_\_\_\_.

3. This horror classic short 7) \_\_\_\_\_ by Edgar Allan Poe is about a man who loves his animals, but then starts mistreating them. One animal he 8) \_\_\_\_\_ in particular is his favorite, the “Black Cat”. What will the cat do?

4. A. Bradley’s “The Sweetness at the Bottom of the Pie” is a book about the 11-years old Flavia de Luce, who suddenly becomes involved in the investigation of the 9) \_\_\_\_\_. An intriguing, captivating, fascinating and dynamic 10) \_\_\_\_\_ about the crime, justice, curiosity and interpersonal relations.

5. The wild rush of action in this classic 11) \_\_\_\_\_ story has made “The Last of the Mohicans” the most 12) \_\_\_\_\_ of James Fenimore Cooper’s Leatherstocking Tales. Deep in the forests of upper New York State, the brave woodsman Hawkeye and his loyal Mohican friends become involved in the bloody 13) \_\_\_\_\_ of the French and Indian War.

**2. Match the genres of the books from the previous exercise.**

The Lord of the Flies	A. Adventure, war;
Emma	B. Horror story
The Black Cat	C. Romance
The Sweetness at the Bottom of the Pie	D. Adventure story
The Last of the Mohicans	E. Detective Story

**Lesson 49**

**1. Rewrite the following sentences as it is given in the model. Make the necessary changes to the structure of the sentences.**

*Model: There is not anything to eat in the fridge.*

**Nothing:** *There is nothing to eat in the fridge.*

1. You are not allowed to come late to the classes.

**Should not:** \_\_\_\_\_

2. I would like to speak with the library clerk to clarify some questions.

**Assistant:** \_\_\_\_\_

3. Mark will bring the cakes for the birthday party.

**Will be brought:** \_\_\_\_\_

4. The teacher decided to count the amount of students before starting a lesson:

**The noses:** \_\_\_\_\_

5. I often use the electronic catalogue of the local library to get information about its books.

**Online:** \_\_\_\_\_

6. There is no one in this room, who can speak Chinese.

**Anybody:** \_\_\_\_\_

7. The builders will reconstruct this house at the end of the month.

**Reconstructed:** \_\_\_\_\_

8. The pupils are not allowed to take pets to school.

**Should not:** \_\_\_\_\_

9. The teacher asks us to clean the classroom after the lessons.

**Are asked:** \_\_\_\_\_

**2. Put the verbs in brackets into the correct voice form.**

1. The visitors \_\_\_\_\_ (allow) to walk on the grass.
2. The parents \_\_\_\_\_ (allow) their son to eat an ice-cream.
3. Littering \_\_\_\_\_ (prohibit) inside and outside of the House of Parliament.
4. The law \_\_\_\_\_ (prohibit) littering on the streets.
5. My mum \_\_\_\_\_ (forbid) eating too much chocolate, as it is harmful for the health.
6. Taking pictures at the state borders \_\_\_\_\_ (forbid) by the international law.
7. The administrator of the shop \_\_\_\_\_ (permit) to taste the samples of food before buying it.
8. Walking the pets in the parks \_\_\_\_\_ (not permit).

**3. Match the literature genres with their descriptions.**

<input type="checkbox"/>	1. Romance	A. a subgenre of crime fiction in which a detective investigates a crime.
<input type="checkbox"/>	2. Adventure story	B. a type of short story that typically features folkloric fantasy characters, such as dwarves, elves, fairies, giants, mermaids, etc.
<input type="checkbox"/>	3. Detective story	C. a traditional story, especially one concerning the early history of a people or explaining a natural or social phenomena.
<input type="checkbox"/>	4. Science fiction	D. genre of fiction in which an adventure, an exciting undertaking involving risk and physical danger are described.
<input type="checkbox"/>	5. Fairy tale	E. a genre of fiction dealing with imaginative concepts such as futuristic science and technology, space travel, etc.
<input type="checkbox"/>	6. Myth	F. A type of literature that deals with topics of love, especially in an idealized form.

**Lesson 50 (optional)**

# Unit V. MUSIC IN OUR LIFE

## Lesson 51

1. Solve the crossword puzzle.

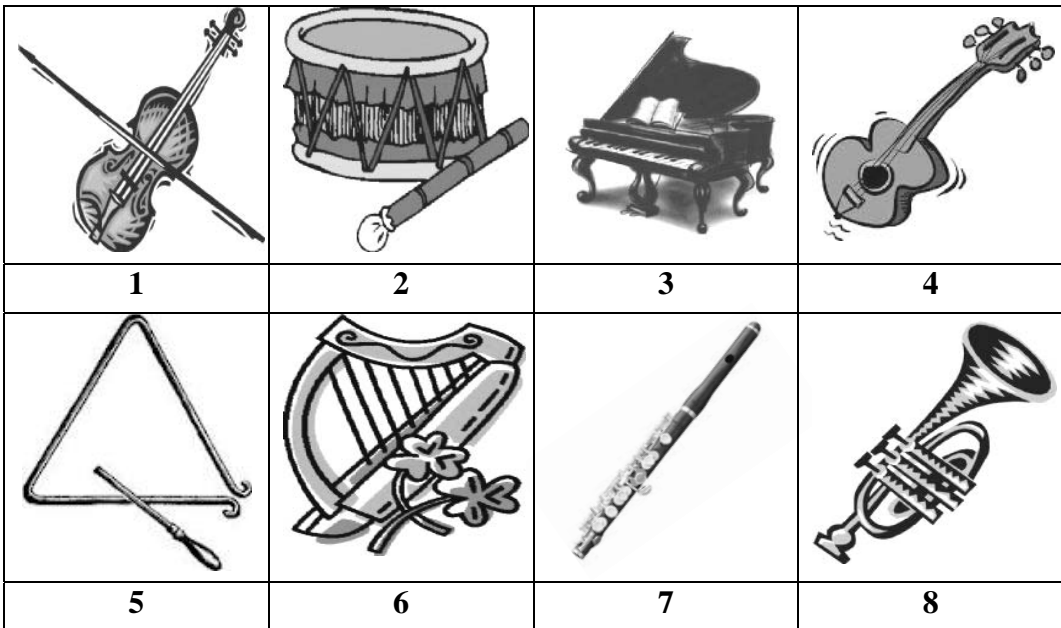
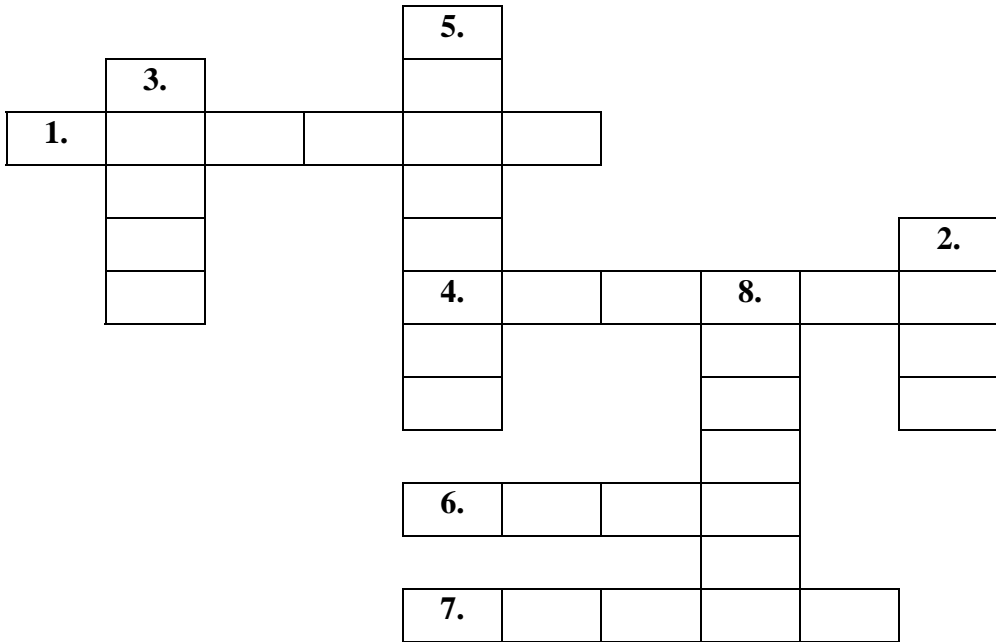

**2. Fill in the gaps with the names of the musical instruments from the previous exercise.**

1. Many African tribes use \_\_\_\_\_ as the national musical instrument to accompany the traditional dances.
2. Different musical movements and trends use the sound of the \_\_\_\_\_, so there exist different subtypes of this instrument.
3. The Ryanair airline company has chosen \_\_\_\_\_ as its emblem.
4. Antonio Stradivari's \_\_\_\_\_ are famous and respected all over the world.
5. One needs to do many breathing exercises to play the \_\_\_\_\_ properly and skilfully.
6. In our school, we have a big \_\_\_\_\_, which is used during the concerts in the concert hall.
7. I like the sound of the \_\_\_\_\_, as it is always very cheerful, loud, energetic and bright.
8. Some people do not distinguish between the similar woodwind musical instruments, such as, for example, the \_\_\_\_\_ and the piccolo.

**3. Match the names of the famous artists with the names of instruments they play. Use the Internet to help you.**

<input type="checkbox"/> Vanessa May	A. piano
<input type="checkbox"/> Irith Gabriely	B. saxophone
<input type="checkbox"/> Tommy Lee	C. clarinet
<input type="checkbox"/> Ludovico Einaudi	D. drums
<input type="checkbox"/> Jimi Hendrix	E. violin
<input type="checkbox"/> Nancy Lendrim	F. harp
<input type="checkbox"/> Lester Young	G. guitar

## Lesson 52

**1. Make up words out of the letter combinations, meaning the names of musical instruments.**

1. i o l v n i -

2. a i n p o -

3. t a g u r i -

4. t u l f u -

5. d u r m s -

6. p r h a -

7. l l e c o -

8. x p h o s a n e -

9. p e t r m t u -

10. r i c l n e a t -

**2. Find the names of the musical instruments in the box of letters below.**

n	v	i	o	l	i	n	t	r	m
p	a	u	h	h	y	g	b	u	k
i	w	c	r	a	v	u	e	x	n
a	c	c	o	r	d	i	o	n	t
n	t	e	h	p	s	t	b	y	r
o	f	l	u	t	e	a	k	x	u
t	t	l	b	g	l	r	j	m	m
v	i	o	o	d	r	u	m	s	p
b	s	a	x	o	p	h	o	n	e
b	n	c	l	a	r	i	n	e	t

- |           |          |
|-----------|----------|
| Violin    | Guitar   |
| Piano     | Trumpet  |
| Accordion | Flute    |
| Saxophone | Clarinet |
| Cello     | Drums    |
| Harp      |          |

## Lesson 53

**1. Fill in the gaps with the words from the box below.**

<i>Tunes</i>	<i>recorded</i>	<i>lyrics</i>	<i>whistle</i>
<i>catchy</i>	<i>instrumental</i>	<i>beat</i>	

1. When I listen to the foreign songs, I don't always understand the \_\_\_\_\_. So I have to find the text to understand the sense of the song.
2. I like to listen to jazz \_\_\_\_\_, though my favourite musical genre is the blues.

3. My sister visited a concert of the symphonic orchestra recently, as she is really keen on the \_\_\_\_\_ music.

4. If I don't know the lyrics of the song, I try to \_\_\_\_\_ the melody.

5. The new Adele's song is really \_\_\_\_\_. I keep singing it for the entire day.

6. The concerts of some musicians are very expensive. Fortunately, it is also possible to listen to the \_\_\_\_\_ songs as well.

7. Latin songs have a very energetic and dynamic \_\_\_\_\_, so that I can't stop dancing.

**2. Provide the words for the following definitions.**

1. The text or script of a song composition – \_\_\_\_\_

2. A succession of musical sounds forming an air or melody: – \_\_\_\_\_

3. A performance given by one or more singers or instrumentalists or both in a real time – \_\_\_\_\_

4. To produce a clear musical sound by forcing air through the teeth– \_\_\_\_\_

5. The music intended to be performed by a musical instrument or group of instruments – \_\_\_\_\_

6. Attractive, appealing and easily remembered – \_\_\_\_\_

7. A pattern of sounds that produces the rhythm – \_\_\_\_\_

8. To join in singing with a performer – \_\_\_\_\_

## Lesson 54

**1. Sort out the adjectives into the columns in the table to describe the given music genres.**

Fast, lively, energetic, relaxing, calm, heavy, slow, monotonous, repetitive, romantic, aggressive, vivid, dynamic, dancing, up-beat, passive, cheerful, tranquil, melodic, sad, orchestral, melancholic, nostalgic, dreaming, loud, jazzy, funky, catchy, mysterious, active, instrumental.

Classical	Country	Folk	Jazz	Rock	Latin	Hip-hop

**2. Decide which genre of music is suitable for the following situations.**

*Model: Jogging – In my opinion, hip-hop or pop music is good for jogging.*

1. Studying – \_\_\_\_\_
2. Dancing – \_\_\_\_\_
3. Working out in the gym – \_\_\_\_\_
4. Doing shopping – \_\_\_\_\_
5. Visiting a folk festival – \_\_\_\_\_
6. Working in the garden – \_\_\_\_\_
7. Walking around the city – \_\_\_\_\_
8. Meeting with the friends – \_\_\_\_\_
9. Driving the car – \_\_\_\_\_
10. Preparing to sleep – \_\_\_\_\_

**3. Choose the right word to fill in the gaps.**

1. Yesterday, I visited a concert of the symphonic orchestra, where I could enjoy relaxing, fascinating \_\_\_\_\_ (instrumental/ country) music.

2. She has been practising the Latin dances for five years, so she knows plenty of \_\_\_\_\_ (rap/ Latin) songs and artists.

3. This year, during a handicraft festival, the visitors could taste the traditional dishes and listen to the \_\_\_\_\_ (classical/ folk) music, performed by the local bands.



4. It is almost impossible to imagine \_\_\_\_\_ (jazz/ folk) compositions without the sounds of the saxophone.

5. When I do the physical exercises, I like to listen to the up-beat music, such as, for example \_\_\_\_\_ (hip-hop/ blues) or country.

6. I am always amused to listen to the modern interpretations of the \_\_\_\_\_ (pop/ classical) music.

## Lesson 55

### **1. Provide the synonyms for the following words.**

1. A melody – \_\_\_\_\_

2. Lyrics – \_\_\_\_\_

3. A song – \_\_\_\_\_

4. Up-tempo – \_\_\_\_\_

5. Melancholic – \_\_\_\_\_

6. A genre – \_\_\_\_\_

7. A singer – \_\_\_\_\_

### **2. Read the text and choose the correct item to fill in the gaps.**

#### **The Story Behind Paul McCartney's Song "Let It Be"**

One night, somewhere between deep sleep and 1) \_\_\_\_\_, I had the most comforting dream about my mother, who died when I was only 14. She had been a nurse, my mum, and very hardworking, because she wanted 2) \_\_\_\_\_ for us. We weren't a well-off family – we didn't have a car, we just about had a television – so both of my parents went out to work, and Mum contributed a good half to the family 3) \_\_\_\_\_. At night when she came home, she would cook, so we didn't have a lot of time with each other. But she was just a very comforting presence in my 4) \_\_\_\_\_. And when she died, one of the difficulties I had, as the years went by, was that I couldn't 5) \_\_\_\_\_ her face so easily. That's how it is for everyone, I think. As each day goes by, you just can't bring their face into your 6) \_\_\_\_\_, you have to use photographs and reminders like that.

So in this dream twelve years later, my mother 7) \_\_\_\_\_, and there was her face, completely clear, particularly her eyes, and she said to me very gently, very reassuringly: “Let it be.”

It was lovely. I woke up with a great feeling. It was really like she had visited me at this very difficult point in my life and gave me this 8) \_\_\_\_\_: Be gentle, don’t fight things, just try and go with the 9) \_\_\_\_\_ and it will all work out.

(by Paul McCartney)

- |                 |               |               |                 |
|-----------------|---------------|---------------|-----------------|
| 1. A) dreams;   | B) non-sleep; | C) insomnia;  | D) nap.         |
| 2. A) the best; | B) something; | C) the world; | D) money.       |
| 3. A) come;     | B) outcome;   | C) coming;    | D) income.      |
| 4. A) world;    | B) life;      | C) time;      | D) imagination. |
| 5. A) recall;   | B) remain;    | C) memorize;  | D) understand.  |
| 6. A) head;     | B) mind;      | C) heart;     | D) life.        |
| 7. A) happened; | B) arose;     | C) appeared;  | D) showed.      |
| 8. A) song;     | B) vision;    | C) idea;      | D) message.     |
| 9. A) river;    | B) life;      | C) flow;      | D) people.      |

## Lesson 56

### 1. Fill in the gaps with the idioms from the list below.

<i>to fine-tune</i>	<i>music to one’s ear</i>	<i>change the tune</i>
<i>to blow one’s own trumpet</i>	<i>face the music</i>	
<i>play it by ear</i>	<i>ring a bell</i>	

1. Yesterday, I have received a letter, informing about my admissions to the university. This news was a real \_\_\_\_\_, as I’ve got the great enthusiasm to study there.

2. This tune \_\_\_\_\_, but I can’t recall the name of the singer, who performs it.

3. Liza did not prepare the presentation on time, so she had \_\_\_\_\_ and get additional tasks to complete for the following lesson.

4. He quickly \_\_\_\_\_, when he understood that he was speaking with the head of the National Bank.

5. After winning the sports competition, Artur really \_\_\_\_\_ and tells everyone about his victory.

6. She did not know what to expect from her new boss, so she decided just \_\_\_\_\_.

7. It took us a lot of time to \_\_\_\_\_ the violin before it started to function well.

**2. Replace the underlined expressions in each sentence with the idioms from the previous exercise.**

1. I don't like to boast about my achievements, but the victory in the literary competition makes me very proud and excited.

2. The news about a new music festival, which is going to take place in my city, is a real pleasure for me, as I really enjoy such events.

3. Probably, he will change his behaviour and thinking about this job, when he finds out its advantages and opportunities.

4. The name of this shop sounds very familiar to me. Have we already visited it before?

5. Unfortunately, she had to listen to the critics for not coming to the meeting on time.

## Lesson 57

**1. Read the texts about the famous Ukrainian musicians. Choose the correct word from the brackets to fill in the gaps.**

**Oleksandra Koltsova** is a Ukrainian singer, musician, composer, poet, producer and journalist. She is the leader of the rock band "Kryhitka". In 2001, she \_\_\_\_\_ (left/ graduated from) Kyiv National Linguistic University and started working as a journalist in the local magazine. Since 2007, Oleksandra plays in the rock band, writes songs and participates in numerous festivals and music \_\_\_\_\_

(activities/ events), winning the awards as the best female voice and young performer. Besides the music, Oleksandra plays an active role in the social \_\_\_\_\_ (life/ area) of Ukraine and takes much care of the \_\_\_\_\_ (ecology/ environment). Currently, the band "Kryhitka" is recording their new music album and participating in the \_\_\_\_\_ (entertainment/ charity) events, aiming at the protection of nature and human rights.

**Jamala** is a Ukrainian singer, actress and songwriter. Jamala has been fond of music since her early \_\_\_\_\_ (life/ childhood). She made her first \_\_\_\_\_ (professional/ personal) recording at the age of nine, singing children's Crimean Tatar songs. She \_\_\_\_\_ (entered/ started) the Simferopol Music College and later graduated from Tchaikovsky National Music Academy of Ukraine as an opera singer, but preferred a career in \_\_\_\_\_ (pop/ rock) music. On 14 February 2010, she \_\_\_\_\_ (made/ released) her debut single "You Are Made of Love" as the lead single from her debut studio album. Early in 2011, she took part in the Ukrainian national selection for the Eurovision Song Contest with the song "Smile". The song was a crowd \_\_\_\_\_ (favourite/ choice) and Jamala herself managed to land a spot in the finals of the competition. In 2016, she again \_\_\_\_\_ (showed/ represented) Ukraine and won the Eurovision Song Contest 2016 with the song "1944".

**Sviatoslav Vakarchuk** is the \_\_\_\_\_ (main/ lead) vocalist of Okean Elzy, the most famous and recognized rock band in Ukraine. He is the son of Ivan Vakarchuk, a professor of Physics at Lviv University and the \_\_\_\_\_ (last/ former) Minister of Education and Science in Ukraine. He was active in supporting the Orange Revolution, and is involved in many social and cultural \_\_\_\_\_ (projects/ ideas). He is one of the most successful musicians in Ukraine and has a \_\_\_\_\_ (degree/ certificate) in Theoretical Physics. By the year 2010, he had released 8 studio albums together with his \_\_\_\_\_ (band/ colleagues), Okean Elzy. In the summer of 2014, Okean Elzy had performed a number of large \_\_\_\_\_ (number/ scale) concerts on the biggest stadiums in Ukraine. Their performance in Kyiv on Olimpiyskii Stadium had broken the record for the largest amount of people \_\_\_\_\_ (appreciating / attending) a concert by a Ukrainian band – over 75 thousand.

**2. Mark the sentences as true (T) or false (F). Correct the false ones.**

1. \_\_\_\_ Oleksandra Koltsova has a degree in History.
2. \_\_\_\_ The band “Kryhitka” has existed since 2007.
3. \_\_\_\_ “Kryhitka” does not participate in the music festivals.
4. \_\_\_\_ Oleksandra Koltsova takes an active role in social life of Ukraine.
5. \_\_\_\_ The band “Kryhitka” does not record any new albums, participating exclusively in the charity events.
6. \_\_\_\_ Jamala found her interest in music, when she was already an adult.
7. \_\_\_\_ Jamala has participated in Eurovision Song Contest three times.
8. \_\_\_\_ Jamala chose carrier in pop music and graduated from the university as the pop singer.
9. \_\_\_\_ Jamala released her first single in 2010.
10. \_\_\_\_ Jamala is the winner of the Eurovision Song Contest 2016.
11. \_\_\_\_ Sviatoslav Vakarchuk is the leader of the most successful pop band in Ukraine.
12. \_\_\_\_ The band “Okean Elzy” had released more than 10 studio albums by 2010.
13. \_\_\_\_ Sviatoslav Vakarchuk has obtained the degree in Mathematics.
14. \_\_\_\_ “Okean Elzy” gathered the largest amount of people at one of their concerts.

**3. Match the names of the famous Ukrainian musicians and bands with the photos.**



*Khrystyna Soloviy, Onuka, Tarkak, Lama, Tina Karol, S.K.A.Y.*

## Lesson 58

### 1. Fill in the gaps with the words from the box below.

<i>composers</i>	<i>scholarship</i>	<i>compositions</i>
<i>to follow in the father's footsteps</i>	<i>ethnologist</i>	
<i>obstacles</i>	<i>stage</i>	

1. In his career, M. Lysenko had to overcome many \_\_\_\_\_, one of which was the censorship on Ukrainian art imposed by the government.

2. The international students can apply for the \_\_\_\_\_ in order to be able to pay for the education and living expenses.

3. The classical Ukrainian music \_\_\_\_\_ reveal the topics of love, friendship, nature and life of the peasants.

4. My grandfather was an \_\_\_\_\_, so he could tell us many interesting facts about the history of our region and its traditions.

5. It is said that the city theatre will \_\_\_\_\_ the play, written by a modern Ukrainian writer.

6. Olena would like to become a teacher, but her parents want her \_\_\_\_\_ and choose the profession of a doctor.

7. Many Ukrainian classical \_\_\_\_\_ are well known and respected all over the world.

### 2. Put the words below in the right order to make up sentences in the Passive Voice.

1. Made / of / plastic / these/ are/ bags –

---

2. The doors/ locked/ at / are/ 9 pm –

---

3. Born/ March/ was/ Artem/ on/ 18<sup>th</sup>/ of/ the –

---

4. Will be/ papers/ the/ soon/ read –

---

5. Is/ Spanish/ Latin/ spoken/ America/ widely/ in –

---

6. Will be/ the/ taken/ patient/ the/ hospital/ to –

---

7. Visited/ is/ Germany/ tourists/ many/ by –

---

8. Cheese/ produced/ best/ France/ in/ the/ is –

---

9. Picked/ not/ winters/ apples/ are/ in –

---

10. Was/ last/ bicycle/ stolen/ his/ night –

---

## Lesson 59

### **1. Put the verbs in brackets into the correct tense form in the Passive Voice.**

1. The exercises \_\_\_\_\_ by the teacher today. (explain)
2. The letter \_\_\_\_\_ the day before yesterday/ (send)
3. A new café \_\_\_\_\_ next weekend. (open)
4. She \_\_\_\_\_ to the party last week. (invite)
5. Next time, the dishes \_\_\_\_\_ by my brother. (wash)
6. Today, this street \_\_\_\_\_ because of the snow. (close)
7. I \_\_\_\_\_ a book by my classmate last Saturday. (give)
8. The buses \_\_\_\_\_ with the trolley buses next week. (replace)

### **2. Rewrite the sentences in the Passive Voice.**

1. Kate rescued four cats. – *Four cats were rescued by Kate.*
2. Oksana learnt the poem. – \_\_\_\_\_
3. Steven will take the book tomorrow. – \_\_\_\_\_
4. The children play football. – \_\_\_\_\_
5. She puts the bag on the floor. – \_\_\_\_\_
6. The student will not open the window. – \_\_\_\_\_
7. This team lost the competition. – \_\_\_\_\_

8. The engineer did not repair the laptop. – \_\_\_\_\_
9. The mother will not cook the cake. – \_\_\_\_\_
- I will plant a tree. – \_\_\_\_\_

## Lesson 60

### 1. Sort out the musical instruments into the correct columns.

*Cello, saxophone, electric guitar, tambourine, double bass, flute, trumpet, guitar, bassoon, maracas, xylophone, violin, piano, tuba, bass guitar, clarinet*

String instruments	Wind instruments	Percussion instruments

### 2. Add other musical instruments which belong to the following groups.

1. String family: cello, double bass, ...
2. Woodwind family: oboe, clarinet, ...
3. Brass family: horn, trombone, ...
4. Percussion family: side drum, bass drum, ...

### 3. Choose the best word to fill in the gaps.

1. My friend is playing the \_\_\_\_\_ (saxophone/ electric guitar), and he would like to join the rock band.

2. Jane wanted to play the \_\_\_\_\_ (double bass/ violin), but she is too slim and small to carry this instrument to and from the concerts.

3. Playing the \_\_\_\_\_ (piano/ drums) in the flat is a bad idea, as its loud sound can annoy the neighbours and distract them from their work.

4. My sister likes the sound of the woodwind musical instruments, particularly she enjoys the \_\_\_\_\_ (clarinet/ trombone).



5. The traditional Celtic and Irish melodies are accompanied by the sound of the \_\_\_\_\_ (harp/ violin).

## Lesson 61

**1. Replace the expressions in the sentences with their synonyms from the box.**

<i>released</i>	<i>number</i>	<i>successful</i>
<i>donate</i>	<i>honourable</i>	<i>dignity</i>
	<i>fluently</i>	

1. His father is a respected member and Ukrainian representative of the World Wildlife Fund.

2. My sister has been studying a lot, but now she can speak five languages freely.

3. Nowadays, there are many environmental charity organizations, which take care of our ecology and nature. Everyone can give some money to support their activities.

4. The local council is going to spend a great amount of money on the reconstruction of the city park.

5. This is one of the most effective companies in Ukraine, which deals with the trade.

6. The psychologists state that the feeling of self-respect allows people to become more confident and successful in their personal and professional life.

7. Beyoncé has recently presented a new music album, which contains some new songs and well-known hits, as well.

**2. Decide whether the sentences are written in the Passive or Active Voice.**

1. The oranges are grown in Spain. – *Phe Passive Voice.*

2. Those trees are growing very slowly. \_\_\_\_\_

3. The party started at 8 pm yesterday. \_\_\_\_\_

4. The car is parked in the garage. \_\_\_\_\_

5. My father will park the bicycle near the shopping centre. \_\_\_\_\_

6. The car is put in the garage. \_\_\_\_\_
7. The work will be stopped because of the bad weather. \_\_\_\_\_
8. The toaster stopped working because of the problems with electricity. \_\_\_\_\_
9. The first fast food restaurants were opened in the US. \_\_\_\_\_
10. The window will be open till the end of the working day. \_\_\_\_\_

## Lesson 62

### **1. Read the text and choose the correct item to fill in the gaps.**

**The Sziget Festival** (from Hungarian "Island festival") is one of the largest music and 1) \_\_\_\_\_ festivals in Europe. It is held every August in northern Budapest, Hungary, on a leafy 2) \_\_\_\_\_ on the Danube. More than 1,000 performances take place each year.

The weeklong festival has 3) \_\_\_\_\_ from a relatively low-profile student event in 1993 to become one of the prominent European rock festivals, with about half of all visitors coming from 4) \_\_\_\_\_ Hungary, especially from Western Europe. It also has a dedicated "party train" service (with resident DJs) that 5) \_\_\_\_\_ festivalgoers from all over Europe.

Sziget Festival is notable in that it contains acts from many 6) \_\_\_\_\_ genres. In 2006, a blues stage, a jazz tent, a world music stage were 7) \_\_\_\_\_, alongside the main stage with more typical rock acts.

The festival is popular with west Europeans. 8) \_\_\_\_\_ 50% of visitors come from outside Hungary, with the largest group coming from the Netherlands. Many also come from the UK, Germany, Italy, France and Ireland.

Being 9) \_\_\_\_\_ on an island, some festivalgoers try swimming across the Danube or paddling across in the rafts and canoes.

- |                  |                   |                   |               |
|------------------|-------------------|-------------------|---------------|
| 1. A) cultural   | B) traditional;   | C) international; | D) artistic   |
| 2. A) land;      | B) area;          | C) island;        | D) territory. |
| 3. A) changed;   | B) appeared;      | C) shifted;       | D) grown.     |
| 4. A) outside;   | B) outdoors;      | C) behind;        | D) backwards. |
| 5. A) carries;   | B) transports;    | C) brings;        | D) transfers. |
| 6. A) different; | B) miscellaneous; | C) interesting;   | D) important. |

7. A) shown;            B) decorated;            C) installed;            D) removed  
8. A) total;            B) number;            C) out of;            D) around.  
9. A) standed;            B) held;            C) located;            D) presented.

**2. Mark the sentences as true (T) or false (F). Correct the false ones.**

1. \_\_\_\_\_ Sziget Festival is the biggest music festival in Western Europe. –  
\_\_\_\_\_
2. \_\_\_\_\_ The word “Sziget” means “party” in Hungarian. –  
\_\_\_\_\_
3. \_\_\_\_\_ The first edition of the festival was low-profile and low-financed. –  
\_\_\_\_\_
4. \_\_\_\_\_ Many people from around Europe visit \_\_\_\_\_ Sziget.–  
\_\_\_\_\_
5. \_\_\_\_\_ The majority of the visitors of the festival are Hungarians. –  
\_\_\_\_\_
6. \_\_\_\_\_ The festival presents exclusively rock music. –  
\_\_\_\_\_
7. \_\_\_\_\_ The variety of other activities are available at Sziget Festival. –  
\_\_\_\_\_
8. \_\_\_\_\_ The festival does not take place any more. –  
\_\_\_\_\_

**3. Fill the gaps with the words from the text in exercise 1.**

1. The new rock band has prepared an interesting \_\_\_\_\_, combining the art of music, poetry and cinematography.
2. The majority of the \_\_\_\_\_ prefer camping on the territory of the festival to renting the accommodation in the city.
3. This festival has four different \_\_\_\_\_, dedicated to various genres and styles of music.
4. This region of the country offers \_\_\_\_\_ high salaries and good living conditions, in comparison with the other ones.
5. Pavlo works out in the gym every day. That is why, \_\_\_\_\_ in the raft is not a difficult task for him.

## Lesson 63

### **1. Put questions to the underlined words in the following sentences.**

1. The patient was prepared for the operation. –

---

2. The first computer was invented in the 20<sup>th</sup> century/ –

---

3. The dog will be taken to the vet. –

---

4. The president will be elected next Sunday. –

---

5. The astronauts will be sent to the Moon. –

---

6. The eggs were boiled in hot water. –

---

7. The table will be served by me. –

---

8. Three tigers are kept in the zoo. –

---

9. A new computer element will be produced in Germany. –

---

10. The note is written in pencil. –

---

### **2. Rewrite the sentences in the Active Voice.**

1. The visitors were not warned by the coastguards.

---

2. The old ship will be taken into the harbour by the sailors.

---

3. This song will be performed by the audience.

---

4. The homework will be done tomorrow by me.

---

5. The children were seen in the park by their parents.

---

6. The road will be closed by constructors.

---

**3. Provide the antonyms for the following words.**

1. Slow – \_\_\_\_\_

2. Dynamic – \_\_\_\_\_

3. Classical – \_\_\_\_\_

4. Loud – \_\_\_\_\_

5. Captivating – \_\_\_\_\_

6. Famous – \_\_\_\_\_

7. Traditional – \_\_\_\_\_

8. Relaxing – \_\_\_\_\_

9. Melancholic – \_\_\_\_\_

10. Energetic – \_\_\_\_\_

## Lesson 64 (Optional)

### Unit VI. GREAT BRITAIN AND ITS PEOPLE

#### Lesson 65

**1. Solve the crossword puzzle about the places and people of the United Kingdom.**

1. An English city famous for having two football teams.

2. A famous Scottish lake.

3. The city where *The Beatles* were born.

4. An English city known for its prestigious universities.

5. The Scottish creator of Harry Potter.

6. A town in the South West of England on the River Exe.

7. The Scottish castle of the Royal Family.

8. One of the Queen's sons.

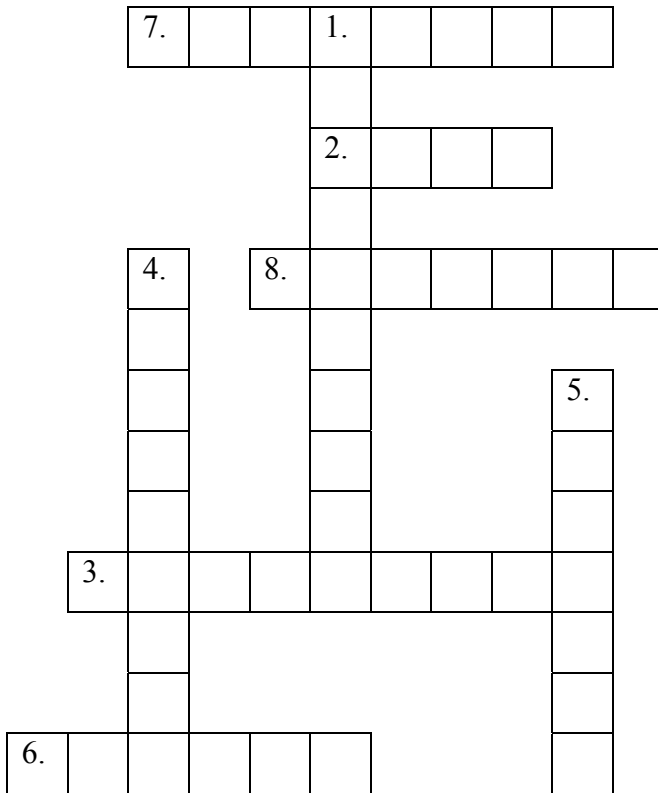

**2. Look at the pictures of famous symbols of the UK. Match them with their names.**

*a. Big Ben, b. Umbrella, c. English tea, d. London phone booth, e. UK flag*

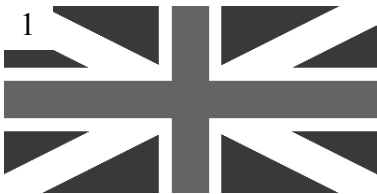

## Lesson 66

### 1. Choose the correct item to complete the sentences.

1. The Spanish beaches and coastlines are very beautiful, though in summers they are very \_\_\_\_\_, because many people want to visit them.

- A) quiet;      B) ugly;      C) crowded;      D) overpopulated.

2. My grandparents would like to live in the countryside, as the city is too \_\_\_\_\_ for them.

- A) noisy;      B) peaceful;      C) ugly;      D) dull.

3. When we came to Valencia, we were looking for the \_\_\_\_\_ town to observe the beauty of the ancient buildings and temples.

- A) modern;      B) interesting;      C) old;      D) former.

4. This small city is very \_\_\_\_\_. You can't go out in the evening with your friends, because it does not offer any entertainment.

- A) peaceful;      B) exciting;      C) crowded;      D) boring.

5. These mountainous landscapes look so \_\_\_\_\_. You can't see the signs of human activities here.

- A) busy;      B) peaceful;      C) noisy;      D) dull.

6. It was totally \_\_\_\_\_ to observe the beauty of the Carpathian mountains in summer.

- A) exciting;      B) beautiful;      C) interesting;      D) quiet.

7. My friend lives in a \_\_\_\_\_ city, so he prefers spending the weekends and holidays in the quiet countryside areas.

- A) boring;      B) ugly;      C) busy;      D) lively.

8. You can find many \_\_\_\_\_ sightseeing and tourist attractions in Germany.

- A) noisy;      B) interesting;      C) peaceful;      D) pretty.

### 2. Provide the antonyms for the given words.

1. Old – \_\_\_\_\_

6. Dull – \_\_\_\_\_

2. Lively – \_\_\_\_\_

7. Interesting – \_\_\_\_\_

3. Crowded – \_\_\_\_\_

8. Small – \_\_\_\_\_

4. Busy – \_\_\_\_\_

9. Pretty – \_\_\_\_\_

5. Exciting – \_\_\_\_\_

10. Noisy – \_\_\_\_\_

**3. Complete the sentences with the information about yourself. Use the words from the previous exercises (1 and 2).**

1. I live in a \_\_\_\_\_ city, but I would prefer to live in the \_\_\_\_\_ area.
2. I like spending my holidays and free time in \_\_\_\_\_ places.
3. I like to visit the seaside, when the sea resorts are \_\_\_\_\_.
4. I don't like \_\_\_\_\_, because I prefer spending time in the \_\_\_\_\_ areas.
5. I would like to visit some old cities to enjoy the \_\_\_\_\_ sightseeing.
6. Sometimes, I spend time in the countryside and enjoy its \_\_\_\_\_ atmosphere.

### Lesson 67

**1. Describe the two landscapes below with as many adjectives as possible.**



*Peaceful, quiet, ...*

---

---

---

---

---

---

---

---

---

---

---

---

---





**2. Choose the correct answer.**

1) Great Britain includes:

- A. England, Scotland, Wales;
- B. Wales, Northern Ireland, England;
- C. England, Scotland, Wales, Northern Ireland.

2) The capital city of the UK is:

- A. Cardiff;
- B. London;
- C. Edinburgh.

3) The flag of the UK is called:

- A. Stars and stripes;
- B. The Union Jack;
- C. The Crossed One.

4) The flag is comprised of:

- A. red, white and green;
- B. red, white and yellow;
- C. white, blue and red.

5) The symbol of England is:

- A. a rose;
- B. a leek;
- C. a thistle.

6) The symbol of Wales is:

- A. a rose;
- B. a leek;
- C. a thistle.

7) The symbol of Scotland is:

- A. a rose;
- B. a leek;
- C. a thistle.

## Lesson 68

**1. Put notes on the map. Include the names of the countries of the UK, seas and oceans around them.**



### **2. Choose the correct item to fill in the gaps.**

1. In many European countries, the university programs consist of the \_\_\_\_\_ and optional subjects.  
A) essential; B) compulsory.
2. The new system of taxes will be \_\_\_\_\_ next year.  
A) introduced; B) regulated.
3. Sorting out the garbage and using various containers for the trash are the \_\_\_\_\_ in Sweden.  
A) common practices; B) common ideas.
4. The doctors have to complete at least 6 years of studies to be \_\_\_\_\_ as the professionals.  
A) presented; B) qualified.
5. My father has \_\_\_\_\_ for the scholarship for doing the scientific research in economics.  
A) applied; B) imposed.

6. Before telling me her secret, Olena made me \_\_\_\_\_ that I would not tell it to anyone else.

A) speak;

B) swear.

7. The \_\_\_\_\_ of the European Union do not need visas to cross the borders within the Schengen area.

A) people;

B) citizens.

## Lesson 69

**1. Read the text about the Welsh music, food and symbols. Fill in the gaps with the suitable word in brackets.**

### Welsh Traditions

#### Music

The Welsh people love music and there are a lot of \_\_\_\_\_ (singing/ music) festivals and competitions in Wales. One of the \_\_\_\_\_ (most popular/largest) cultural festivals in Europe is the National Eisteddfod of Wales, which takes place in a \_\_\_\_\_ (new/different) town or city every year. All the events are in Welsh and \_\_\_\_\_ (comprise/include) literature, music, art, exhibitions, dance and theatre.

#### Food

There are lots of sheep in Wales, so people eat a lot of \_\_\_\_\_ (lamb/ pork). Typical Welsh \_\_\_\_\_ (cuisines/ dishes) include 'cawl' (the lamb stew), Glamorgan sausages and 'rarebit' (a type of cheese on toast).

#### Symbols

If you ever go to Wales, you will see dragons \_\_\_\_\_ (somewhere/ everywhere)! Not real dragons, of course, but a red dragon appears on the national \_\_\_\_\_ (flag/ emblem) of Wales. The Patron Saint of Wales is Saint David, who is \_\_\_\_\_ (celebrated/ dedicated) on March 1st. Other symbols of Wales include the leek (a long green \_\_\_\_\_ (fruit/ vegetable)) and the daffodil (a white or yellow \_\_\_\_\_ (tree/ flower)).

**2. Mark the sentences as true (T) or false (F). Correct the false ones.**

1. \_\_\_\_\_ At the National Eisteddfod people sing in English. –

2. \_\_\_\_\_ The red dragon is a symbol of Wales. –

3. \_\_\_\_\_ Welsh people do not like to eat much meat. –

4. \_\_\_\_\_ There are many plant symbols in Wales. –

5. \_\_\_\_\_ The national dishes of Wales include the meat of sheep. –

6. \_\_\_\_\_ National Eisteddfod of Wales always takes place in the same city. –

7. \_\_\_\_\_ There are many dragons in Wales. –

**3. Write down the names to the following Welsh symbols.**



## Lesson 70

**1. Match the words about the weather from two columns to have the pairs of synonyms.**

1. Blustery	A. Cool
2. Freezing	B. Pleasant
3. Chilly	C. Windy
4. Dark	D. Light
5. Nice	E. Gloomy
6. Wet	F. Hot
7. Scorching	G. Cloudy
8. Melting	H. Thawing
9. Overcast	I. Icy
10. Bright	J. Rainy

**2. Choose the words from the previous exercise to fill in the gaps.**

1. The weather in Great Britain can vary from the \_\_\_\_\_ temperatures to the \_\_\_\_\_ heat.
2. Psychologists state that people feel more depressed in the \_\_\_\_\_ weather.
3. This year the spring came very early, and the snow started \_\_\_\_\_ at the beginning of March.
4. The weather can be quite \_\_\_\_\_ near the seaside and ocean coastlines, because of the strong waves and wind.
5. In Great Britain, the summer days are commonly \_\_\_\_\_ and \_\_\_\_\_.
6. The most \_\_\_\_\_ weather in Great Britain occurs in the late spring and mid-autumn. This is the best time to visit this country.

## Lesson 71

**1. Mark the statements about Northern Ireland as true (T) or false (F). Correct the false ones.**

1. \_\_\_\_\_ Northern Ireland is a part of Great Britain. –

---

2. \_\_\_\_\_ Another name for Northern Ireland is 'Ulster'. –

---

3. \_\_\_\_\_ The 'Giant's Causeway' was created by a volcano. –

---

4. \_\_\_\_\_ Two languages are spoken in Northern Ireland. –

---

5. \_\_\_\_\_ Only Irish musicians and bands play at summer music festivals in Belfast. –

---

6. \_\_\_\_\_ There are many opportunities for the adventure sports in Northern Ireland. –

---

7. \_\_\_\_\_ In Gaelic football it's fine to touch the ball with your hands. –

---

8. \_\_\_\_\_ The 'Ulster Fry' is not a healthy dish. –

---

9. \_\_\_\_\_ A shamrock has four leaves on each stem. –

---

**2. Put the words in the correct order to form the sentences:**

1. Another/ is/ name/ Ulster/ for/ Northern Ireland:

---

2. The/ place/ Giant's/ Causeway/ a / is/ very/ beautiful:

---

3. Languages/ two/ Northern Ireland/ in/ are/ there:

---

4. Popular/ sports/ football/ are/ Northern Ireland/ in/ most/ rugby/ and/ the.

---

5. And/ Fry/ the/ is made with/ bacon/ Ulster/ potato bread/ eggs/ and/ sausages.

---

6. People/ concerts/ celebrate/ with/ St. Patrick's/ parades/ and/ Day.

---

## Lesson 72

### 1. Choose the correct answers.

- 1) In which Scottish lake is Nessie supposed to live?
  - A. Loch Lomond;
  - B. Loch Ness;
  - C. Loch Awe.
- 2) What is the capital of Scotland?
  - A. Edinburgh;
  - B. Inverness;
  - C. Glasgow.
- 3) What is the national symbol of Scotland?
  - A. shamrock;
  - B. rose;
  - C. thistle.
- 4) Who is the Patron saint of Scotland?
  - A. St. Andrew;
  - B. St. Georg;
  - C. St. Patrick.
- 6) Who was Queen of Scotland?
  - A. Queen Victoria (1837 - 1901);
  - B. Queen Mary (1542 - 1587);
  - C. Queen Elisabeth I (1558 - 1603).
- 7) What is the traditional Scottish dish Haggis eaten with?
  - A. potatoes and turnips;
  - B. chips and carrots;
  - C. Potatoes and cauliflower.
- 8) What is the Royal Mile in Scotland?
  - A. the street between Edinburgh Castle and the Palace of Holyrood House;
  - B. the distance for races with sailing boats in Scotland;
  - C. the name of a festival in Edinburgh.

9) When does the Military Tattoo in Edinburgh take place?

- A. May;
- B. August;
- C. October.

10) Which is the oldest university in Scotland founded in 1413?

- A. St. Andrews;
- B. Edinburgh;
- C. Dundee.

**2. Read the statements about the symbols of Scotland and correct mistakes in the sentences.**

1. Blue is the colour, which is often associated with the Scotland.
2. The Scottish flag of blue with a white X-shaped cross called the Saint Andrew's cross.
3. St. Andrew is the Patron Saint of Scotland and his day is celebrating on November 30th.
4. Everywhere you goes in Scotland, you will see tartan, kilts and bagpipes.
5. Also, look out for the national animal (the unicorn) and the thistle – the purple fruit of Scotland.
6. Scotland is knowed for its variety of seafood such as lobsters and oysters, salmon and trout.

**3. Use the model to write down the data about Scotland.**

*Model: The land of Scotland occupies seventy seven thousand and nine hundred thirty-three square kilometres.*

Land	Population	Date of formation	Income of citizens	Density of population
77, 933 km <sup>2</sup>	5,373,000	9 <sup>th</sup> century	\$45,904	67,5 km <sup>2</sup>

1. \_\_\_\_\_
2. \_\_\_\_\_
3. \_\_\_\_\_
4. \_\_\_\_\_



## Lesson 73

**1. Match the names of major London sightseeing attractions with their descriptions.**

<input type="checkbox"/> Big Ben	A. one of five London bridges now owned and maintained by the Bridge House Estates;
<input type="checkbox"/> Thames	B. residence and administrative headquarters of the reigning monarch of the United Kingdom;
<input type="checkbox"/> Tower Bridge;	C. the nickname for the Great Bell of the clock at the north end of the Palace of Westminster in London;
<input type="checkbox"/> Buckingham Palace	D. a giant Ferris wheel on the South Bank of the River Thames in London;
<input type="checkbox"/> Trafalgar Square	E. a public square in the City of Westminster, Central London, built around the area formerly known as Charing Cross;
<input type="checkbox"/> London Eye	F. a river that flows through southern England.

**2. Learn more facts about London by answering the questions. Consult the Internet, if necessary.**

1. What's London's most famous department store?
  - A. Picadilly;
  - B. Harrods;
  - C. The Barbican Centre;
2. What street has a long tradition as the home of printing?
  - A. Sloane Street;
  - B. Oxford Street;
  - C. Fleet Street.
3. What are the famous guards of The Tower of London called?
  - A. Beefeaters;

- B. The Guards;
  - C. Knights.
4. What commemorates Napoleon's defeat at sea in 1805?
- A. Oliver's Column;
  - B. Duke of York's Column;
  - C. Nelson's Column.
5. What line runs through Greenwich?
- A. Nine Elms Lane;
  - B. The Prime Meridian;
  - C. Long Lane.
6. Where's the home of the Prime Minister and the Chancellor of the Exchequer?
- A. Downing Street 10 and 11;
  - B. Regent Street 10 and 11;
  - C. Browning Street 10 and 11
7. What made Carnaby Street famous?
- A. Food;
  - B. Flowers;
  - C. Fashion.
8. What did Madame Tussaud start in 1835?
- A. A famous bakery;
  - B. Famous waxworks;
  - C. A famous needle-point.
9. Who wrote famous books in 48 Doughty Street?
- A. R. L. Stine;
  - B. Charles Dickens;
  - C. Agatha Christie.
10. St. Paul's Cathedral has the \_\_\_\_\_ dome in the world.
- A. Biggest;
  - B. Second biggest;
  - C. Third biggest.

## Lesson 74

**1. Read the text about Celtic music and put the verbs in brackets into the correct passive tense form.**

### What is Celtic Music?

Celtic music is a broad grouping of music genres that \_\_\_\_\_ (evolve) out of the folk music traditions of the Celtic people of Western Europe. It \_\_\_\_\_ (derive) from both orally transmitted traditional songs and recorded compositions. Traditional music and various hybrids \_\_\_\_\_ also \_\_\_\_\_ (include) into a wide range of Celtic music styles.

Often, the term Celtic music \_\_\_\_\_ (apply) to the music of Ireland and Scotland because both lands \_\_\_\_\_ (know) for the distinctive styles. Modern music \_\_\_\_\_ (term) as "Celtic" because it \_\_\_\_\_ (write) and \_\_\_\_\_ (record) in the Celtic language, regardless of musical style. Many festivals of Celtic music \_\_\_\_\_ (hold) annually, all around the world. Breton artist Alan Stivell \_\_\_\_\_ (consider) as one of the most successful performers of the Celtic music. He \_\_\_\_\_ (invite) to numerous festivals every year.

**2. Complete the sentences with your own ideas. Use exercise 1 to help you.**

1. Celtic music is originally the music of \_\_\_\_\_ .
2. Celtic music comprises both \_\_\_\_\_ .
3. Modern variations and styles are also parts of the \_\_\_\_\_ .
4. Many Celtic festivals take place \_\_\_\_\_ .
5. One of the most famous Celtic singers is \_\_\_\_\_ .

**3. Write down all words concerned with the music from exercise 1.**

A genre, modern music, \_\_\_\_\_

## Unit VII. UKRAINE

### Lesson 75

#### 1. Choose the correct item to fill in the gaps.

- Many factors \_\_\_\_\_ our musical preferences.  
A) change;                      B) influence.
- This non-governmental organization aims at the protection of \_\_\_\_\_ rights and freedom.  
A) human;                      B) people's.
- The traditional fuels strongly pollute the \_\_\_\_\_. That is why many car owners prefer using the biodegradable gas.  
A) air;                      B) atmosphere.
- \_\_\_\_\_ is an essential element of fresh water, which helps to maintain life on the Earth.  
A) ozone;                      B) oxygen.
- I have to study hard, \_\_\_\_\_ I will fail the exam.  
A) otherwise;      B) unless.
- My mother is a very \_\_\_\_\_ person. She never follows any spontaneous ideas.  
A) active;                      B) moderate.
- I can listen to \_\_\_\_\_ styles of music, depending on my mood.  
A) various;                      B) similar.

#### 2. Match the words with their definitions.

1. Carbon dioxide	A. The process in which gases in the atmosphere can't leave the Earth and heat it;
2. Atmosphere	B. A gas with the chemical name CO <sub>2</sub> ;
3. Oxygen	C. The process of changing of the climate over a long period of time;
4. The greenhouse effect	D. The scientific word for "air";
5. Environment	E. A system of plants and animals living together;
6. Eco-system	F. The gas, essential for human breathing.
7. Global warming	G. The surroundings or conditions in which a person, animal, or plant lives.

## Lesson 76

1. Find words about Ukraine in the box of letters below.

d	n	i	p	r	o	r	u	y	t
e	g	f	d	i	d	f	b	b	e
s	r	a	s	a	e	a	l	f	r
n	b	e	a	r	s	f	v	h	n
a	z	o	v	i	a	u	i	o	o
n	u	g	t	k	y	i	v	v	p
l	u	t	s	k	l	w	l	e	i
p	r	y	p	i	a	t	p	r	l
d	g	n	y	a	o	l	t	l	r
c	a	r	p	a	t	h	i	a	n

*Dnipro, Kyiv, Ternopil, Lviv, Desna, Azov, Odesa,  
Carpathian, Hoverla, Lutsk, Prypiat*

2. Complete the statements about Ukraine.

1. The capital of Ukraine is \_\_\_\_\_
2. Ukraine has borders with \_\_\_\_\_ countries.
3. On the West, Ukraine shares borders with \_\_\_\_\_
4. The highest peak of Ukraine is \_\_\_\_\_
5. Ukraine's national language is \_\_\_\_\_
6. Ukraine is washed by \_\_\_\_\_ seas. They are \_\_\_\_\_
7. The biggest rivers in Ukraine are \_\_\_\_\_
8. The Ukrainian Carpathian mountains are situated \_\_\_\_\_
9. The climate of Ukraine is mostly \_\_\_\_\_
10. The biggest industrial cities of Ukraine are \_\_\_\_\_

## Lesson 77

**1. Match the name of the Natural Wonders of Ukraine with their descriptions.**

Svitiaz Lake	A. Natural steppe area, which preserves hundreds of the endangered species of flora and fauna;
Hranitno-Stepove Pobuzhzhia	B. A 250-kilometre stretch of the Dnister River from the Zolota Lypa River to the Zbruch River;
Ascania Nova	C. The biggest and deepest lake in Ukraine;
Marble Cave	D. A national park, which is situated on the plain territory and possesses many valuable mineral waters;
Synevyr lake	E. A rocky canyon of the River Pivdenny Buh;
Podilsky Tovtry	F. the most beautiful cave among other natural caves in the Crimean Mountains;
Dnistrovsky Canyon	G. A lake situated in the Transcarpathian area.

**2. Turn the sentences into the passive voice in Present Perfect:**

1. They have eaten some hamburgers. – \_\_\_\_\_
2. The expedition has found a new cave. – \_\_\_\_\_
3. They have read the book. – \_\_\_\_\_
4. The police has caught the thief. – \_\_\_\_\_
5. The post officer has delivered a parcel. – \_\_\_\_\_
6. I have opened a birthday gift. – \_\_\_\_\_
7. They have watched a new movie. – \_\_\_\_\_
8. The company has solved the problem. – \_\_\_\_\_
9. The volunteer has done this job. – \_\_\_\_\_
10. She has noticed a beautiful bird. – \_\_\_\_\_

## Lesson 78

### 1. Fill in the gaps with the words from the box below.

<i>river</i>	<i>hill</i>	<i>continental</i>
<i>weeping</i>	<i>willow</i>	<i>coastline</i>
<i>Canyon</i>	<i>steppe</i>	<i>cave</i>
<i>waterfall</i>		<i>pond</i>

1. The \_\_\_\_\_ is the line, where the land meets the ocean or the sea.
2. There are no high mountains in my region, but there are some \_\_\_\_\_, which are suitable for hiking.
3. The vast part of Ukraine is situated in the \_\_\_\_\_ climate zone.
4. There are many plant symbols in the Ukrainian traditions, one of which is the \_\_\_\_\_.
5. One of the major natural sightseeings in the US is the Grand \_\_\_\_\_.
6. The \_\_\_\_\_ is the area, which is covered mainly with grass and low plants, in the opposition to the forests.
7. There is a unique salt \_\_\_\_\_ in Slovenia, where some endangered species of animals live.
8. This artificial \_\_\_\_\_ is a good place for swimming in summer.
9. In the ancient times, people tried to build cities near big \_\_\_\_\_ to have sufficient water supplies.
10. Despite the popular beliefs, the Niagara Fall is not the biggest \_\_\_\_\_ on Earth.

### 2. Provide the words for the given definitions.

1. A \_\_\_\_\_ is a large area of water that flows toward the ocean or the sea.
2. A \_\_\_\_\_ is a large area of water surrounded by land.
3. A \_\_\_\_\_ is a large area of land that is covered with trees.
4. A \_\_\_\_\_ is a mountain, which results from the rise of magma.
5. A \_\_\_\_\_ is a large natural elevation of the earth's surface.
6. A \_\_\_\_\_ is a large underground chamber in a hillside or cliff.

## Lesson 79

### 1. Correct mistakes in the following sentences.

1. I have been give a book by my parents.
2. Has the films been already watched?
3. They been invited to the birthday party.
4. Who has been ask to answer this question?
5. The candies have been not sold out from the shop.
6. The chocolate has not been eaten yet.
7. Has the door been opening?
8. This task hasn't finished by his colleague yet.

### 2. Match the beginning of the phrase with its ending to make up the Ukrainian superstitions.

If you accidentally scatter the salt on the table,	A. you will soon welcome the guests.
If there is a spoon on the table,	B. the whole life will be in debts.
If the spoon falls down,	C. you will have a bad luck during the day.
If you borrow money on Thursday,	D. you will have an argument with your friends.
If there is a very bright moon in the sky,	E. somebody is in the rush.
If you forget to take something and return back,	F. the following day will be very cold.

## Lesson 80

### 1. Guess which Ukrainian cities are described below.

Lviv, Odesa, Kyiv, Chernivtsi, Poltava

1. It is a big international city, situated on the coast of the Black sea. There is a big port and many beautiful beaches in this city. \_\_\_\_\_

2. This city is known for its stunning university, which prepares thousands of students for their professional activities. The city is the bright representative of Bukovyna, the ethnical territory of Ukraine. \_\_\_\_\_

3. King Danylo founded this city and named it in honour of his son. This city combines the architecture of different Western states and remains one of the most popular tourist destinations in Ukraine. \_\_\_\_\_



4. This city is an administrative, political, cultural and economic centre of Ukraine. It is situated on the river Dnipro and is surrounded by the beautiful nature. \_\_\_\_\_

5. This city was the centre of the Ukrainian culture and literature in the 9<sup>th</sup> century. Now, it is known for its peaceful parks, beautiful gardens and ancient churches. \_\_\_\_\_

**2. Mark the sentences below as true (T) or false (F). Correct the false ones.**

1. \_\_\_\_\_ Lviv is situated in the centre of Ukraine. – \_\_\_\_\_
2. \_\_\_\_\_ Kyiv has always been the capital of Ukraine. – \_\_\_\_\_
3. \_\_\_\_\_ Dnipro is a big industrial city in the east of Ukraine. – \_\_\_\_\_
4. \_\_\_\_\_ Odesa has the access to the Black Sea. – \_\_\_\_\_
5. \_\_\_\_\_ Chernivtsi is a part of ethnical land of Halychyna. – \_\_\_\_\_
6. \_\_\_\_\_ Lviv was under the occupation of Poland and Germany throughout its history. – \_\_\_\_\_
7. \_\_\_\_\_ Poltava is located in the west of Ukraine. – \_\_\_\_\_
8. \_\_\_\_\_ Uzhgorod is the regional centre of the Transcarpathian region. – \_\_\_\_\_
9. \_\_\_\_\_ Poltava hasn't got any ancient temples and churches nowadays. – \_\_\_\_\_
10. \_\_\_\_\_ There is a big artificial pond in the middle of Ternopil. – \_\_\_\_\_

**3. Write down the population of the biggest Ukrainian cities.**

*Model: The population of Kyiv is two million eight hundred forty seven thousand and two hundred citizens.*

Kyiv	Kharkiv	Dnipro	Odesa	Lviv	Zaporizhia
2,847,200	1,470,902	1,065,008	1,029,049	732,818	815,256

1. \_\_\_\_\_
2. \_\_\_\_\_
3. \_\_\_\_\_
4. \_\_\_\_\_
5. \_\_\_\_\_

## Lesson 81

**1. Read the text about the Opera Theatre in Lviv and choose the correct item to fill in the gaps.**

### Lviv Opera Theatre

The Solomiya Krushelnytska Lviv State Academic Theatre of Opera and Ballet is an opera 1) \_\_\_\_\_ located in Lviv, Ukraine's largest western city and one of its historic cultural 2) \_\_\_\_\_. Originally built on the Poltva River, the Lviv Opera now 3) \_\_\_\_\_ at the end of Freedom Avenue.

At the end of the 19th century, 4) \_\_\_\_\_ leaders felt the need for a large city theatre to be situated in the capital of Galicia. In 1895, the city 5) \_\_\_\_\_ an architectural design competition, which attracted a large number of submissions. An independent jury chose the 6) \_\_\_\_\_ by Zygmunt Gorgolewski, a graduate of the Berlin Building Academy and the director of city's Engineering Academy. Gorgolewski pleasantly surprised the jury by planning to 7) \_\_\_\_\_ the building in the centre of the city.

The Lviv Theatre of Opera and Ballet is built in the 8) \_\_\_\_\_ tradition with the forms and details of Renaissance and Baroque architecture. The theatre beautifully decorated inside and outside became a centrefold of the 9) \_\_\_\_\_ in sculpture and painting of Western Europe at the end of the 19th century.

1. A) building;      B) house;      C) construction;      D) apartment.
2. A) centres;      B) nucleus;      C) middle;      D) downtown.
3. A) stays;      B) lies;      C) sits;      D) stands.
4. A) local;      B) political;      C) neighboring;      D) city.
5. A) showed;      B) presented;      C) announced;      D) introduced.
6. A) suggestion;      B) plan;      C) idea;      D) design.
7. A) locate;      B) place;      C) park;      D) put.
8. A) conventional;      B) classical;      C) ordinary;      D) used.
9. A) heights;      B) effects;      C) results;      D) achievements.

**2. Fill in the gaps with the words from the box below.**

<i>attracted</i>	<i>graduate</i>	<i>submissions</i>
<i>local leaders</i>	<i>Independent Jury</i>	<i>Renaissance</i>

1. The city park has been reconstructed and renovated due to the efforts of the \_\_\_\_\_.
2. Every year, the admission committee of Oxford University gets plenty of \_\_\_\_\_ from students from all over the world.
3. The weather is so pleasant today, so that I am highly \_\_\_\_\_ by the idea of bicycling around the lake.
4. Leonardo da Vinci, Michelangelo, Sandro Botticelli are bright representatives of the epoch of \_\_\_\_\_.
5. Dr. Abrams, \_\_\_\_\_ of Harvard Univeristy, has recently presented a new book in psychology.
6. The winners of the literary competitions will be chosen and announced by the \_\_\_\_\_.

## Lesson 82

### 1. Match the natural phenomena with their names.

*a volcano, a cave, a river, the sea, a hill, a mountain*

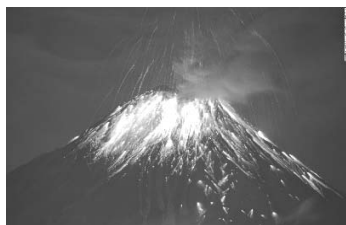

### 2. Put special questions to the following sentences.

1. The candies have been bought for the birthday party.  
*What have the candies been bought for?*
2. The mobile phone has been broken because of my sudden movement.

---

3. The workers have been granted with the better salaries.

---

4. The trees have been chopped down.

---

5. These clothes have been designed by my mother.

---

6. The theatre has been opened recently.

---

7. The house has been renovated.

---

8. The money has been successfully transferred to another account.

---

9. The village has been rebuilt in just five years.

---

10. The animals have been recently fed by the zoo keeper.

---

### Lesson 83

**1. Find sentences written in the Passive Voice. Turn them into the Active Voice.**

The students have been given some tasks.	The children have given their paintings to the parents.	The workers have already completed this work.
The lamp has been installed near the desk.	The musician has invited his parents to the concert.	The visitors have watched the performance for the first time.

**2. Turn the sentences about Lesia Ukrayinka into the Ppassive Voice.**

1. Her parents educated their children at home.

---

2. The Russified School negatively influenced the education of children.

---

3. In 1881, Lesia went to see the colourful celebration on Vodokhreshcha.

---

4. At that celebration, she developed the tuberculosis of bones.

---

5. Her parents and uncle taught her many interesting things.

---

6. Lesia spent her last years mostly abroad.

---

7. Lesia did not choose her penname accidentally.

---

8. Lesia always composed soft and kind poems about her native land.

---

9. Lesia wrote “The Forest Song” in just eleven days.

---

10. This work reflected her thoughts and soul.

**3. Put the words in the right order to make up the sentences.**

1. Picture/ has/ a/ he/ drawn.

---

2. School/ mother/ has/ picked me up/ from/ my/ recently.

---

3. Been/ cars/ already/ have/ produced/ new/ the.

---

4. The visitors/ have/ commentaries/ been/ by/ written/ the/ not.

---

5. Sent/ been/ yet/ money/ the/ has/ not.

---

6. Caught/ police/ the/ has/ by/ thief/ officer/ the/ been.

---

7. The dishes/ table/ not/ have/ placed/ been/ the/ on.

---

8. By/ window/ the/ wind/ has/ opened/ been/ the.

---

## Lesson 84 (Optional)

### Unit VIII. MASS MEDIA: NEWSPAPERS AND MAGAZINES

#### Lesson 85

##### 1. Match the words with their definitions.

1. An interview	A. The means of communication that reach large numbers of people, such as television, newspapers, and radio;
2. The career	B. A conversation, in which the reporter wants to get facts or statements from another person;
3. A celebrity	C. To get in touch with; communicate with;
4. Mass media	D. A chosen pursuit; a profession or occupation;
5. To contact	E. One who is widely known and of great popular interest.

##### 2. Fill in the gaps with quite or rather.

1. The people he works with are \_\_\_\_\_ intelligent.
2. My brother is a good student, but he is \_\_\_\_\_ deconcentrated.
3. This job is well paid, but it is \_\_\_\_\_ complicated.
4. Germany is an ideal place for the winter vacations. It is \_\_\_\_\_ pleasant.
5. He must go to a dancing competition soon. He has \_\_\_\_\_ good movements.
6. The performance was captivating, but \_\_\_\_\_ tiresome.
7. Your suggestion is \_\_\_\_\_ impossible. I would not support it.

8. They will \_\_\_\_\_ go on foot, than wait for such a long time.
9. The continuation of this book is \_\_\_\_\_ amusing.
10. This job is \_\_\_\_\_ specific, so I would not risk taking it.

## Lesson 86

**1. Your friend wants to become a journalist. Write down several recommendations on how to get the needed skills. Use the prompts given below.**

*Model: You should study foreign languages.*

Learn about digital technologies, make influential connections, volunteer at the local newspaper during holidays, practice writing, read many books, communicate with people, take interviews, search for the useful information on the Internet, study foreign languages.

1. \_\_\_\_\_
2. \_\_\_\_\_
3. \_\_\_\_\_
4. \_\_\_\_\_
5. \_\_\_\_\_
6. \_\_\_\_\_
7. \_\_\_\_\_
8. \_\_\_\_\_
9. \_\_\_\_\_

**2. Fill in the gaps with the appropriate prepositions.**

*Model: The journalists need to learn about the effective ways of communication to succeed in their careers.*

1. It is a good idea for journalists to work \_\_\_\_\_ the local newspaper to obtain the professional experience.
2. The professional journalists need to be successful \_\_\_\_\_ writing articles.
3. If you want to choose a career \_\_\_\_\_ media, you should study hard.
4. The ability to communicate \_\_\_\_\_ people is of paramount importance for the journalists.

5. The ability to communicate \_\_\_\_\_ foreign language is considered as an asset for the media workers.

**3. Decide, which of the following skills and activities are important for the journalists.**

*Driving a car, communicating with the people, writing scientific articles, fishing, surfing the Internet, working with the electronic devices, dancing, mountain-climbing, reading books, visiting media lectures, watching the daily news, recording interviews, video and photo shooting, knitting, singing, speaking foreign languages, working out in the gym.*

Of paramount importance	Of minor importance

## Lesson 87

**1. Fill in the gaps with the words from the box below.**

<i>interviews</i>	<i>editor</i>	<i>daily papers</i>
<i>front page</i>	<i>sports section</i>	<i>online news</i>
<i>advertisement</i>	<i>financial section</i>	

1. My grandmother is a regular subscriber of the \_\_\_\_\_. In such a way, she gets fresh news every day without leaving her home.

2. Have you already read in the \_\_\_\_\_ about the victory of N. Djokovic in the prestigious tennis competition?

3. The position of \_\_\_\_\_ demands high professionalism, patience and good understanding of the target audience.



4. You can read about the latest updates in the monetary services of the state in the \_\_\_\_\_ of the newspaper.

5. I like cinema and I have decided to buy this newspaper, as I've noticed the picture of Jenifer Lawrence on the \_\_\_\_\_.

6. I like to read about the celebrities, but some \_\_\_\_\_ are rather boring and predicted.

7. Everyone can order an \_\_\_\_\_ in the daily paper.

8. Many people buy the printed editions of the newspapers; however, I prefer looking through the \_\_\_\_\_.

**2. Fill in the gaps with quite or rather:**

1. Our football team plays \_\_\_\_\_ well.

2. Our tennis player managed to win the game. It was \_\_\_\_\_ unbelievable.

3. This cake is \_\_\_\_\_ big, in comparison with the previous ones.

4. This was \_\_\_\_\_ a pleasant evening with the live concert.

5. This yellow car is \_\_\_\_\_ old.

6. This athlete can jump \_\_\_\_\_ high.

7. Last week, the weather was \_\_\_\_\_ rainy and cold.

## Lesson 88

**1. Replace the underlined words with their synonyms from the box below.**

<i>behaviour</i>	<i>break into</i>
<i>private life</i>	<i>public</i>
<i>scandal</i>	

1. The new fashion tendencies reflect the common ideas of the modern society.

2. Liza is a very active child. Her parents say that sometimes her manners are unbearable.

3. Many celebrities prefer not speaking about their personal lives in public interviews.

4. There was a great quarrel between the inhabitants of the new house, because of the broken façade.

5. In the 5<sup>th</sup> century, the Roman warriors invaded Great Britain.

**2. Name the types of media, described in the pictures.**



a. \_\_\_\_\_



b. \_\_\_\_\_



c. \_\_\_\_\_



d. \_\_\_\_\_



e. \_\_\_\_\_



f. \_\_\_\_\_

## Lesson 89

**1. Choose the right word to complete the sentences.**

1. This footballer is *quite/rather* famous in his country.
2. The viewers met the musicians *quite/rather* warmly.
3. I like Shakespeare, but many of his plays are *quite/rather* sad.
4. I *quite/rather* agree with you in this question.
5. It was *quite/rather* a long journey from Ukraine to Germany.
6. My mum gave me *quite/rather* a long list for shopping.
7. You look *quite/rather* happy today.
8. You look *quite/rather* depressed today.
9. My father drives *quite/rather* slowly to avoid any road accidents.
10. The movie was *quite/rather* interesting, but not memorable.

## 2. Sort out the given words into following categories.

*A journalist, the magazine, a pen, the Internet, the editor, a newspaper, the television, the interviewer, the laptop, the radio, a phone, a tablet, the correspondent, the paper, the reporters, the telegram, social networks, the media worker, the assistant.*

Types of media	Professions	Instruments/devices

## Lesson 90

### 1. Match the words with their definitions.

1. A celebrity	A. a person who conducts an interview;
2. A photographer	B. the means of communication that reach large numbers of people;
3. The paparazzi	C. the state of being public, or open to general observation or knowledge;
4. The interviewer	D. a person whose occupation is journalism;
5. The journalist	E. One who is widely known and of great popular interest;
6. The media	F. a photographer who pursues celebrities to take pictures for sale to magazines and newspapers;
7. The publicity	G. a person who takes photographs, either as a hobby or a profession.

**2. Choose the correct to fill in the gaps.**

1. The new book of J. Rowling has received the widespread \_\_\_\_\_.

- A) popularity;                      B) publicity.

2. The \_\_\_\_\_ are invited to participate in a 2-day workshop, dedicated to the questions of digital technologies in media.

- A) students;                      B) journalists.

3. The \_\_\_\_\_ have shown a great interest to the questions of human rights and protection of the environment.

- A) media;                      B) newspapers.

4. A periodical paperback publication containing articles, fiction, photographs is called the \_\_\_\_\_.

- A) journal;                      B) magazine

5. My sister was very nervous before her first job \_\_\_\_\_.

- A) interview;                      B) application.

6. The journalists cannot work in media, if they do not possess excellent \_\_\_\_\_ skills.

- A) communicative;                      B) talkative.

7. The world of media has changed a lot after the invention of the \_\_\_\_\_.

- A) tablets;                      B) Internet

8. My friend has a picture with a real \_\_\_\_\_.

- A) celebrity;                      B) paparazzi.

9. The journalists try to place the most dramatic news stories and pictures on the \_\_\_\_\_ to attract the attention of the readers.

- A) headline;                      B) front page.

## Lesson 91

**1. Read the text and write down the numbers given in the brackets in words to complete the sentences.**

### 2016 Social Media Statistics Update

The name of the most popular social network worldwide prepared by *Statista* gives a clear picture with Facebook ruling supreme. This won't be a shock to anyone! With over \_\_\_\_\_ (1,590) million active users, it holds an \_\_\_\_\_ (18%) market share, \_\_\_\_\_ (7%) more than its closest competitor, the Facebook-owned, WhatsApp.

Besides, it is estimated that the other most popular social networks include WhatsApp with about \_\_\_\_\_ (1,000,000,000) users and Instagram, which involves about \_\_\_\_\_ (420,000,000) active users. A great percentage of popularity belong also to Tumblr (\_\_\_\_\_ 6%) and Twitter (\_\_\_\_\_ 4%).

*TrackMaven* analysed \_\_\_\_\_ (51 million) posts from \_\_\_\_\_ (40,000) different companies to learn which social networks achieve the greatest popularity. The results show that Instagram absolutely dominates when it comes to communication with the clients. However, no one doubts the outstanding position of Facebook, which manages to remain on the first place, during a long period already.

**2. Mark the statements as true (T) or false (F). Correct the false ones.**

1. \_\_\_\_\_ Facebook has become the most popular social network in 2016. – \_\_\_\_\_  
\_\_\_\_\_
2. \_\_\_\_\_ Facebook holds more than 20% of the market share. – \_\_\_\_\_  
\_\_\_\_\_
3. \_\_\_\_\_ The WhatsApp application is owned by Twitter. – \_\_\_\_\_  
\_\_\_\_\_
4. \_\_\_\_\_ More than 4 hundred million subscribers use Instagram. – \_\_\_\_\_  
\_\_\_\_\_
5. \_\_\_\_\_ According to the statistics, Facebook does not have any special position anymore. – \_\_\_\_\_
6. \_\_\_\_\_ The best way to communicate with the clients is to use Twitter. – \_\_\_\_\_  
\_\_\_\_\_
7. \_\_\_\_\_ Twitter is more popular than Tumblr. – \_\_\_\_\_  
\_\_\_\_\_

## Lesson 92

### **1. Choose the correct form of the verbs in brackets to complete the sentences.**

Fiat \_\_\_\_\_ (started/was started) by a group of Italian businessmen in 1899. In 1903, Fiat \_\_\_\_\_ (produced/was produced) 132 cars. Some of these cars \_\_\_\_\_ (exported/were exported) by the company to the United States and Britain. In 1920, Fiat \_\_\_\_\_ (started/was started) making cars at a new factory at Lingotto, near Turin. There was a track on the roof where the cars \_\_\_\_\_ (tested/were tested) by technicians. In 1936, Fiat launched the Fiat 500. This car \_\_\_\_\_ (called/was called) the Topolino – the Italian name for Mickey Mouse. The company grew, and in 1963 Fiat \_\_\_\_\_ (exported/was exported) more than 300,000 vehicles. Today, Fiat is based in Turin, and its cars \_\_\_\_\_ (sold/are sold) all over the world.

### **2. Rewrite the sentences in the Passive Voice.**

1. The constructors built this house fifty years ago.

---

2. A thief has stolen my wallet.

---

3. The police officer will catch the criminals.

---

4. The hotel serves breakfast at 8 am every morning.

---

5. People throw away plenty of waste every day.

---

6. Many companies make coffee in Africa.

---

7. Someone has broken the glass vase.

---

8. The workers produce 10 new cars every day.

---

9. Peter invited us to the birthday party yesterday.

---

10. My friend has found a mobile phone on the street.

---

## Lesson 93

### **1. Make up sentences in the Passive Voice.**

1. The toothbrush / invent / in the 15th century.

---

2. The first public basketball game / play / in 1892.

---

3. The first eyeglasses / wear / in the 1200s.

---

4. The first bicycle / ride in 1791.

---

5. The first hot dog / eat / in the 1860s.

---

6. The first CDs / sell / in the 1980s.

---

7. The first electric guitar / play / in 1923.

---

8. The first computer mouse / use / 1964.

---

### **2. Fill in the gaps with somebody or anybody.**

1. He knows \_\_\_\_\_, who is working in the automobile company.

2. There is \_\_\_\_\_, standing near the doors.

3. Did \_\_\_\_\_ call me, while I was away?

4. There wasn't \_\_\_\_\_ at home during the reconstruction works.

5. In my opinion, there is \_\_\_\_\_ behind the tree.

6. I wouldn't lend my bicycle to \_\_\_\_\_.

7. Has \_\_\_\_\_ seen my glasses?

8. When we were travelling, we had to ask \_\_\_\_\_ about the directions.

9. I won't tell \_\_\_\_\_ about your secret.

10. Does \_\_\_\_\_ know whose jacket it is?

## Lesson 94

### 1. Choose the correct item to complete the sentence below.

- The professional journalists always put the sensation news on the \_\_\_\_\_.  
A) last page; B) front page; C) middle page.
- Many people have already switched to the online news, but some still subscribe the \_\_\_\_\_.  
A) digital news; B) Internet news; C) online news.
- My mother likes to read \_\_\_\_\_ about celebrities and fashion.  
A) magazines; B) journals; C) newspapers.
- Many celebrities do not want their photos to come into \_\_\_\_\_.  
A) publicity; B) world; C) popularity.
- I don't trust the \_\_\_\_\_ editions, as they can provide some unproved information about celebrities.  
A) quality press; B) tabloids; C) newspapers.
- The \_\_\_\_\_ are responsible for the content of the edition. That is why it is a very hard work.  
A) editors; B) reporters; C) journalists.
- The \_\_\_\_\_ technologies has strongly influenced the popularity of the printed media.  
A) online; B) modern; C) digital.
- The local paper has posted information about the celebration of Easter in the \_\_\_\_\_.  
A) financial section; B) sports section; C) review section.
- The new technologies widely \_\_\_\_\_ our private lives and change our imagination about privacy.  
A) break up; B) break into; C) break down.
- The \_\_\_\_\_ of the article was quite captivating, but the text itself was rather boring.  
A) title; B) headline; C) name.



**2. Choose one word (in the correct form) to complete three sentences in each section.**

1. A) We have a 15-minute \_\_\_\_\_ between the lessons at school.  
B) The social networks actively \_\_\_\_\_ into our private lives.  
C) This car is rather old. Not surprisingly, it \_\_\_\_\_ down last time during our trip.
2. A) This journalist is very skillful in writing the scientific \_\_\_\_\_.  
B) I like to buy different household \_\_\_\_\_ at IKEA.  
C) The indefinite \_\_\_\_\_ is used only with the nouns in singular number.
3. A) My grandparents are the regular subscribers of the daily \_\_\_\_\_.  
B) Can I have another piece of \_\_\_\_\_, please?  
C) In order to apply to the university, you need to prepare all the formal \_\_\_\_\_.
4. A) Last week I lost my \_\_\_\_\_ phone.  
B) The \_\_\_\_\_ of the human body can regenerate quite rapidly.  
C) Many countries have already installed the solar \_\_\_\_\_ to receive the renewable energy.
5. A) Our whole class was invited for the graduation \_\_\_\_\_.  
B) This political \_\_\_\_\_ suggests the increase of the monthly salaries.  
C) The contract about education should be signed by both \_\_\_\_\_.

**Lesson 95**

**1. Rewrite the following passages in the Passive Voice.**

1. Our school is organizing the competition. The students will prepare presentations about the social media. The teachers will choose the best project. The students must include pictures, videos and drawings in their presentations. The students will also have to do all the writing themselves. The school will give the winner a set of books.

---

---

---

---

---

---

---

---

2. My friend has painted this picture. Someone has offered him a lot of money for it. He will deliver the painting tomorrow. When they give him the money, he will tell them the truth. He painted it in one hour!

---

---

---

---

---

---

---

---

---

**2. Fill in the gaps with quite or rather:**

- 1. I was \_\_\_\_\_ uncertain about the plans for the evening.
- 2. My uncle was driving a car \_\_\_\_\_ fast.
- 3. It was \_\_\_\_\_ a long performance, and the viewers felt \_\_\_\_\_ exhausted.
- 4. I haven't tasted this exotic fruit before, but now it tastes \_\_\_\_\_ sweet.
- 5. The new article about Angelina Jolie was \_\_\_\_\_ interesting.
- 6. I \_\_\_\_\_ agree with my parents about the importance of higher education.
- 7. It was \_\_\_\_\_ a rainy day yesterday.
- 8. I was \_\_\_\_\_ embarrassed with this situation.
- 9. The reconstructed part looks \_\_\_\_\_ pleasant.
- 10. The journey to Portugal by plane will be \_\_\_\_\_ short.

# FINAL LESSONS

## Lesson 96

**1. Which of the following objects and natural landscapes can be found in the rural area; urban area; both of them?**

*A block of flats, a field, a meadow, a mountain, a river, an opera house, a cave, a park, a garden, a hill, a shopping mall, a skyscraper, a forest, a hut, a botanic garden, a castle, a lake, a plantations, a restaurant, a museum, a pond, a post office, a school*

Rural area	Urban area	Both

**2. Fill in the gaps with somebody, anybody, nobody, something, anything, and nothing.**

1. Does \_\_\_\_\_ wants to go to the theatre?
2. Would you like \_\_\_\_\_ to eat?
3. Since it's your birthday, you can order \_\_\_\_\_ from the menu.
4. \_\_\_\_\_ can solve this puzzle. It's impossible!
5. Is there \_\_\_\_\_ interesting in the cinema tonight?
6. I don't know \_\_\_\_\_ about the usage of telegram.
7. The movie was in German, so I could understand \_\_\_\_\_ from it.
8. Can \_\_\_\_\_ tell me the capital city of Brazil?
9. I think there is \_\_\_\_\_ near the door.
10. You look upset. Does \_\_\_\_\_ disturb you?

## Lesson 97

### 1. Use the correct tense form of the verbs in brackets.

1. I \_\_\_\_\_ (leave) to Italy for vacations next week.
2. The train \_\_\_\_\_ (depart) at 3 pm.
3. Probably, it \_\_\_\_\_ (rain), because there are many clouds in the sky.
4. My parents \_\_\_\_\_ (visit) their old friends this Saturday.
5. The plane \_\_\_\_\_ (take off) in half an hour.
6. Maybe, I \_\_\_\_\_ (apply) for the history course at this university.
7. My father \_\_\_\_\_ (repair) his car next weekend.
8. The weather \_\_\_\_\_ (be) warmer in a few days.
9. My sister \_\_\_\_\_ (arrive) home tomorrow early in the morning.
10. Probably, this bus \_\_\_\_\_ (arrive) later than planned.

### 2. Match the sentences to make up short conversations.

1. What should I visit when I go to London?	A. We don't want to get lost.
2. You shouldn't go out alone in a new city.	B. You should go to see the Buckingham Palace.
3. We should take a map or the GPS navigator with us.	C. In front of the Trafalgar Square.
4. You shouldn't forget to take an umbrella.	D. We should stay together.
5. Where should we meet you?	E. It frequently rains in London.

## Lesson 98

### 1. Write four sentences giving advice to tourists in your town.

1. You should \_\_\_\_\_
2. You should \_\_\_\_\_
3. You should \_\_\_\_\_

4. You shouldn't \_\_\_\_\_  
5. You shouldn't \_\_\_\_\_

**2. Use the Present Continuous tense form of the verbs in brackets.**

1. He \_\_\_\_\_ (see) his mother on Wednesday.
2. She \_\_\_\_\_ (travel) to New York at the end of this month.
3. We \_\_\_\_\_ (eat) in the café tonight.
4. I \_\_\_\_\_ (meet) some friends after the classes.
5. I \_\_\_\_\_ (not go) to the party tonight.
6. \_\_\_\_\_ he \_\_\_\_\_ (visit) his grandparents next week?
7. She \_\_\_\_\_ (get) married next Saturday.
8. I \_\_\_\_\_ (have) my first guitar lessons this Friday.
9. \_\_\_\_\_ they \_\_\_\_\_ (have) a party at the weekend?
10. \_\_\_\_\_ you \_\_\_\_\_ (meet) with Marta today?
11. Oksana \_\_\_\_\_ (come) for lunch tomorrow.
12. We \_\_\_\_\_ (fly) to Mexico on Saturday.
13. Our grandmother \_\_\_\_\_ (visit) us at Easter.
14. I \_\_\_\_\_ (meet) my mother at the airport.
15. The company \_\_\_\_\_ (give) each worker a bonus for Christmas.

**Lesson 99-105 (Optional)**

## CONTENTS

**REVISION LESSON..... 3**

**Lesson 1 ..... 3**

**Lesson 2 ..... 4**

**Lesson 3 ..... 5**

### **Unit 1.**

**MY FRIENDS ..... 6**

**Lesson 4 ..... 6**

**Lesson 5 ..... 8**

**Lesson 6 ..... 9**

**Lesson 7 ..... 11**

**Lesson 8 ..... 12**

**Lesson 9 ..... 14**

**Lesson 10 ..... 15**

**Lesson 11 ..... 16**

**Lesson 12 ..... 18**

**Lesson 13 ..... 20**

**Lesson 14 ..... 21**

**Lesson 15 (Optional)..... 22**

### **Unit 2.**

**HEALTHY LIFESTYLE... 23**

**Lesson 16 ..... 23**

**Lesson 17 ..... 25**

**Lesson 18 ..... 26**

**Lesson 19 ..... 27**

**Lesson 20 ..... 28**

**Lesson 21 ..... 29**

**Lesson 22 ..... 31**

**Lesson 23 ..... 32**

**Lesson 24 ..... 34**

**Lesson 25 ..... 35**

### **Unit 3.**

**AT THE LIBRARY.**

**READING BOOKS ..... 36**

**Lesson 26..... 36**

**Lesson 27..... 37**

**Lesson 28..... 39**

**Lesson 29..... 41**

**Lesson 30..... 42**

**Lesson 31..... 43**

**Lesson 32..... 44**

**Lesson 33..... 45**

**Lesson 34..... 47**

**Lesson 35..... 49**

**Lesson 36 (Optional)..... 50**

### **Unit IV.**

**SCHOOL LIFE ..... 51**

**Lesson 37..... 51**

**Lesson 38..... 52**

**Lesson 39..... 53**

**Lesson 40..... 54**

**Lesson 41..... 56**

**Lesson 42..... 57**

**Lesson 43..... 58**

**Lesson 44..... 58**

**Lesson 45..... 59**

**Lesson 46..... 61**

**Lesson 47..... 62**

**Lesson 48..... 64**

**Lesson 49..... 65**

**Lesson 50 (optional) ..... 67**

**Unit V.**  
**MUSIC IN OUR LIFE ..... 68**  
**Lesson 51 ..... 68**  
**Lesson 52 ..... 70**  
**Lesson 53 ..... 70**  
**Lesson 54 ..... 71**  
**Lesson 55 ..... 73**  
**Lesson 56 ..... 74**  
**Lesson 57 ..... 75**  
**Lesson 58 ..... 78**  
**Lesson 59 ..... 79**  
**Lesson 60 ..... 80**  
**Lesson 61 ..... 81**  
**Lesson 62 ..... 82**  
**Lesson 63 ..... 84**  
**Lesson 64 (Optional)..... 85**

**Unit VI.**  
**GREAT BRITAIN AND**  
**ITS PEOPLE..... 85**  
**Lesson 65 ..... 85**  
**Lesson 66 ..... 87**  
**Lesson 67 ..... 88**  
**Lesson 68 ..... 90**  
**Lesson 69 ..... 91**  
**Lesson 70 ..... 93**  
**Lesson 71 ..... 94**  
**Lesson 72 ..... 95**  
**Lesson 73 ..... 97**  
**Lesson 74 ..... 99**

**Unit VII.**  
**UKRAINE..... 100**  
**Lesson 75..... 100**  
**Lesson 76..... 101**  
**Lesson 77..... 102**  
**Lesson 78..... 103**  
**Lesson 79..... 104**  
**Lesson 80..... 104**  
**Lesson 81..... 106**  
**Lesson 82..... 107**  
**Lesson 83..... 108**  
**Lesson 84 (Optional)..... 110**

**Unit VIII.**  
**MASS MEDIA: NEWSPAPERS**  
**AND MAGAZINES ..... 110**  
**Lesson 85..... 110**  
**Lesson 86..... 111**  
**Lesson 87..... 112**  
**Lesson 88..... 113**  
**Lesson 89..... 114**  
**Lesson 90..... 115**  
**Lesson 91..... 117**  
**Lesson 92..... 118**  
**Lesson 93..... 119**  
**Lesson 94..... 120**  
**Lesson 95..... 121**

**FINAL LESSONS..... 123**  
**Lesson 96..... 123**  
**Lesson 97..... 124**  
**Lesson 98..... 124**  
**Lesson 99-105 (Optional).... 125**

Liliya Morska

# English 8

## Workbook

*Робочий зошит до підручника*  
*«Англійська мова. 8 клас»*  
*(автор Лілія Морська)*

Фахове редагування *Наталії Бахурської*  
Редактор *Анатолій Саган*  
Комп'ютерна верстка *Марії Логош*  
Обкладинка *Інни Малявської*

---

Підписано до друку 22.09. 2017 р. Формат 70x100 1/16.  
Папір офсетний. Гарнітура Arial. Друк офсетний.  
Умовно-друк. арк. 14,88 Облік.-видавн. арк. 3,49.

ТзОВ «Видавництво Астон» м. Тернопіль, вул. Гайова, 8  
тел. (0352) 52-71-36, 43-47-12, факс: 43-47-13 моб. (067) 3546295  
Свідоцтво ТР №28 від 09.06.2005  
**www.aston.te.ua, e-mail: tovaston@gmail.com**  
**тел. (067) 3546295**

Віддруковано в ТзОВ «Гал-Друк», м. Тернопіль, вул. Бродівська, 44  
E-mail: Gal-druk@ukr.net